



Avaya Ethernet Routing Switch 5000 Series Installation

6.0
NN47200-300, 04.07 (217461-C, Rev. 04)
June 2012

Notice

While reasonable efforts have been made to ensure that the information in this document is complete and accurate at the time of printing, Avaya assumes no liability for any errors. Avaya reserves the right to make changes and corrections to the information in this document without the obligation to notify any person or organization of such changes.

Documentation disclaimer

Avaya shall not be responsible for any modifications, additions, or deletions to the original published version of this documentation unless such modifications, additions, or deletions were performed by Avaya. End User agree to indemnify and hold harmless Avaya, Avaya's agents, servants and employees against all claims, lawsuits, demands and judgments arising out of, or in connection with, subsequent modifications, additions or deletions to this documentation, to the extent made by End User.

Link disclaimer

Avaya is not responsible for the contents or reliability of any linked Web sites referenced within this site or documentation(s) provided by Avaya. Avaya is not responsible for the accuracy of any information, statement or content provided on these sites and does not necessarily endorse the products, services, or information described or offered within them. Avaya does not guarantee that these links will work all the time and has no control over the availability of the linked pages.

Warranty

Avaya provides a limited warranty on this product. Refer to your sales agreement to establish the terms of the limited warranty. In addition, Avaya's standard warranty language, as well as information regarding support for this product, while under warranty, is available to Avaya customers and other parties through the Avaya Support Web site: <http://www.avaya.com/support>. Please note that if you acquired the product from an authorized Avaya reseller outside of the United States and Canada, the warranty is provided to you by said Avaya reseller and not by Avaya.

Licenses

THE SOFTWARE LICENSE TERMS AVAILABLE ON THE AVAYA WEBSITE, [HTTP://SUPPORT.AVAYA.COM/LICENSEINFO/](http://support.avaya.com/licenseinfo/) ARE APPLICABLE TO ANYONE WHO DOWNLOADS, USES AND/OR INSTALLS AVAYA SOFTWARE, PURCHASED FROM AVAYA INC., ANY AVAYA AFFILIATE, OR AN AUTHORIZED AVAYA RESELLER (AS APPLICABLE) UNDER A COMMERCIAL AGREEMENT WITH AVAYA OR AN AUTHORIZED AVAYA RESELLER. UNLESS OTHERWISE AGREED TO BY AVAYA IN WRITING, AVAYA DOES NOT EXTEND THIS LICENSE IF THE SOFTWARE WAS OBTAINED FROM ANYONE OTHER THAN AVAYA, AN AVAYA AFFILIATE OR AN AVAYA AUTHORIZED RESELLER, AND AVAYA RESERVES THE RIGHT TO TAKE LEGAL ACTION AGAINST YOU AND ANYONE ELSE USING OR SELLING THE SOFTWARE WITHOUT A LICENSE. BY INSTALLING, DOWNLOADING OR USING THE SOFTWARE, OR AUTHORIZING OTHERS TO DO SO, YOU, ON BEHALF OF YOURSELF AND THE ENTITY FOR WHOM YOU ARE INSTALLING, DOWNLOADING OR USING THE SOFTWARE (HEREINAFTER REFERRED TO INTERCHANGEABLY AS "YOU" AND "END USER"), AGREE TO THESE TERMS AND CONDITIONS AND CREATE A BINDING CONTRACT BETWEEN YOU AND AVAYA INC. OR THE APPLICABLE AVAYA AFFILIATE ("AVAYA").

Copyright

Except where expressly stated otherwise, no use should be made of materials on this site, the Documentation(s) and Product(s) provided by Avaya. All content on this site, the documentation(s) and the product(s) provided by Avaya including the selection, arrangement and design of the content is owned either by Avaya or its licensors and is

protected by copyright and other intellectual property laws including the sui generis rights relating to the protection of databases. You may not modify, copy, reproduce, republish, upload, post, transmit or distribute in any way any content, in whole or in part, including any code and software. Unauthorized reproduction, transmission, dissemination, storage, and or use without the express written consent of Avaya can be a criminal, as well as a civil, offense under the applicable law.

Third-party components

Certain software programs or portions thereof included in the Product may contain software distributed under third party agreements ("Third Party Components"), which may contain terms that expand or limit rights to use certain portions of the Product ("Third Party Terms"). Information regarding distributed Linux OS source code (for those Products that have distributed the Linux OS source code), and identifying the copyright holders of the Third Party Components and the Third Party Terms that apply to them is available on the Avaya Support Web site: <http://www.avaya.com/support/Copyright/>.

Trademarks

The trademarks, logos and service marks ("Marks") displayed in this site, the documentation(s) and product(s) provided by Avaya are the registered or unregistered Marks of Avaya, its affiliates, or other third parties. Users are not permitted to use such Marks without prior written consent from Avaya or such third party which may own the Mark. Nothing contained in this site, the documentation(s) and product(s) should be construed as granting, by implication, estoppel, or otherwise, any license or right in and to the Marks without the express written permission of Avaya or the applicable third party.

Avaya is a registered trademark of Avaya Inc.

All other trademarks are the property of their respective owners.

Downloading documents

For the most current versions of documentation, see the Avaya Support Web site: <http://www.avaya.com/support>

Contact Avaya Support

Avaya provides a telephone number for you to use to report problems or to ask questions about your product. The support telephone number is 1-800-242-2121 in the United States. For additional support telephone numbers, see the Avaya Web site: <http://www.avaya.com/support>

Contents

Chapter 1: New in this Release	5
Features.....	5
Other changes.....	5
Document changes.....	5
5600 Series power options.....	5
Chapter 2: Regulatory information and safety precautions	7
International regulatory statements of conformity.....	7
Russia, Belarus, and Kazakhstan Requirement.....	7
National electromagnetic compliance (EMC) statements of compliance.....	8
FCC statement (USA Only).....	8
ICES statement (Canada only).....	8
CE marking statement (Europe only).....	8
VCCI statement (Japan/Nippon only).....	9
BSMI statement (Taiwan only).....	10
Chinese EMI and safety warnings.....	10
MIC notice (Republic of Korea only).....	11
National safety statements of compliance.....	11
National Environmental Statements of Compliance.....	12
Restriction on Hazardous Substances Directive Compliance Statement.....	13
WEEE Directive Compliance Statement.....	13
Translations of safety messages.....	13
Safety messages.....	13
Chapter 3: Introduction	17
Chapter 4: Installation fundamentals	19
Electrostatic discharge prevention.....	19
Ethernet Routing Switch 5000 series models.....	20
Placement options and cables.....	25
Connecting a transceiver to the switch or switch stack.....	34
Preparing for power requirements of the switch.....	36
5500 Series power options.....	38
5600 Series power options.....	41
Ordering the phone dongle.....	44
Chapter 5: Installing the switch	45
Installation tasks.....	45
Installation Preparation.....	47
Switch placement.....	47
Power connection.....	48
Hardware installation verification.....	49
Preparations for network connectivity.....	50
IP address information configuration.....	51
Stack configuration.....	53
Chapter 6: Procedures for installation of the switch	57
Installation preparation.....	57
Switch placement.....	62

Power connection.....	70
Hardware installation verification.....	75
Preparations for network connectivity.....	79
IP address information configuration.....	81
Stack configuration.....	85
Chapter 7: Common procedures.....	93
Abandoning a command.....	93
Chapter 8: Installation reference.....	95
RJ-45 connector pin assignments.....	95
Avaya Ethernet Routing Switch 5520-24T-PWR and 5520-48T-PWR.....	97
Power specifications.....	98
Chapter 9: Customer Service.....	101
Getting technical documentation.....	101
Getting product training.....	101
Getting help from a distributor or reseller.....	101
Getting technical support from the Avaya Web site.....	102

Chapter 1: New in this Release

The following sections detail what's new in *Avaya Ethernet Routing Switch 5000 Series Installation* (NN47200-300) for Release 6.0.

- [Features](#) on page 5
- [Other changes](#) on page 5

Features

This document includes Ethernet Routing Switch 5000 Series functionality enhancements and changes provided with the introduction of the 5600 Series switch.

Other changes

See the following section for information about changes that are not feature-related:

- [Document changes](#) on page 5
- [5600 Series power options](#) on page 5

Document changes

This document is modified to align with Avaya Customer Documentation Standards. For more information about these standards, see *Avaya Ethernet Routing Switch 5000 Series Documentation Roadmap* (NN47200-103).

5600 Series power options

This document is modified to update the section 5600 Series power options.

New in this Release

Chapter 2: Regulatory information and safety precautions

This module contains the international regulatory statements of conformity and safety precautions and translations for the Avaya Ethernet Routing Switch 5500 Series.

International regulatory statements of conformity

This is to certify that the Ethernet Routing Switch 5500 Series equipment was evaluated to the international regulatory standards for electromagnetic compliance (EMC) and safety and were found to have met the requirements for the following international standards:

- EMC - Electromagnetic Emissions - CISPR 22, Class A
- EMC - Electromagnetic Immunity - CISPR 24
- Electrical Safety - IEC 60950, with CB member national deviations

Further, the equipment has been certified as compliant with the national standards as detailed below.

For regulatory statements of conformity and safety precautions and translations for the Ethernet Routing Switch 5600 Series, see Avaya Ethernet Routing Switch 5600 Series Regulatory Information (NN47201-101).

Russia, Belarus, and Kazakhstan Requirement

В целях соблюдения действующего законодательства, продукты Компании Авайя, которые поставляются в Россию, Белоруссию и Казахстан, поставляются с конфигурацией, которая соответствует текущим требованиям нормативных актов. Любые изменения предустановленного программного обеспечения или прошивки программно-аппаратного комплекса, включая установку иной прошивки, запрещаются, а в случае таких изменений, лицо или компания их осуществившие несут ответственность на свой страх и риск. Компания Авайя не несет ответственности за внесение каких-либо изменений в продукт, произведенный на или для использования на территории России, Белоруссии и Казахстана, кроме модификаций, которые выполнены и сертифицированы Компанией Авайя.

In order to comply with existing laws, Avaya's products that are supplied to Russia, Belarus, and Kazakhstan are supplied with a configuration which is in line with existing legislation. Modifications may lead to product certifications becoming invalid. Any modification of preinstalled software and firmware, including installation of other or more current firmware or software, therefore is done at the responsibility of the person or company executing the changes. Avaya is not responsible for any modifications to the product made on or for use on

the territory of Russia, Belarus and Kazakhstan other than modifications executed and certified by Avaya itself.

National electromagnetic compliance (EMC) statements of compliance

FCC statement (USA Only)

This equipment has been tested and found to comply with the limits for a Class A digital device, pursuant to Part 15 of the Federal Communications Commission (FCC) rules. These limits are designed to provide reasonable protection against harmful interference when the equipment is operated in a commercial environment. This equipment generates, uses, and can radiate radio frequency energy. If it is not installed and used in accordance with the instruction manual, it may cause harmful interference to radio communications. Operation of this equipment in a residential area is likely to cause harmful interference, in which case users will be required to take whatever measures may be necessary to correct the interference at their own expense.

ICES statement (Canada only)

Canadian Department of Communications Radio Interference Regulations

This digital apparatus (Ethernet Routing Switch 5500 Series) does not exceed the Class A limits for radio-noise emissions from digital apparatus as set out in the Radio Interference Regulations of the Canadian Department of Communications.

Règlement sur le brouillage radioélectrique du ministère des Communications

Cet appareil numérique (Ethernet Routing Switch 5500 Series) respecte les limites de bruits radioélectriques visant les appareils numériques de classe A prescrites dans le Règlement sur le brouillage radioélectrique du ministère des Communications du Canada.

CE marking statement (Europe only)

EN 55022 statements

This is to certify that the Ethernet Routing Switch 5500 Series equipment is shielded against the generation of radio interference in accordance with the application of Council Directive 2004/108/EC. Conformity is declared by the application of EN 55022 Class A (CISPR 22).

⚠ Caution:

This device is a Class A product. In a domestic environment, this device can cause radio interference, in which case the user may be required to take appropriate measures.

EN 55024 statement

This is to certify that the Ethernet Routing Switch 5000 Series equipment is shielded against the susceptibility to radio interference in accordance with the application of Council Directive 2004/108/EC. Conformity is declared by the application of EN 55024 (CISPR 24).

EN 300386 statement

The Ethernet Routing switch 5500 Series complies with the requirements of EN 300386 V1.3.3 for emissions and for immunity for a Class A device intended for use in either Telecommunications centre or locations other than telecommunications centres given the performance criteria as specified by the manufacturer.

European Union and European Free Trade Association (EFTA) notice

	All products labeled with the CE marking comply with R&TTE Directive (1999/5/EEC) which includes the Electromagnetic Compliance (EMC) Directive (2004/108/EC) and the Low Voltage Directive (2006/95/EC) issued by the Commission of the European Community.
-----------------------------------------------------------------------------------	--------------------------------------------------------------------------------------------------------------------------------------------------------------------------------------------------------------------------------------------------------------

Compliance with these directives implies conformity to the following European Norms (ENs). The equivalent international standards are listed in parenthesis.

- EN 55022 (CISPR 22)–Electromagnetic Interference
- EN 55024 (IEC 61000-4-2, -3, -4, -5, -6, -8, -11)–Electromagnetic Immunity
- EN 61000-3-2 (IEC 61000-3-2)–Power Line Harmonics
- EN 61000-3-3 (IEC 61000-3-3)–Power Line Flicker

VCCI statement (Japan/Nippon only)

This is a Class A product based on the standard of the Voluntary Control Council for Interference (VCCI) for information technology equipment. If this equipment is used in a domestic environment, radio disturbance may arise. When such trouble occurs, the user may be required to take corrective actions.

この装置は、情報処理装置等電波障害自主規制協議会（VCCI）の基準に基づくクラスA情報技術装置です。この装置を家庭環境で使用すると電波妨害を引き起こすことがあります。この場合には使用者が適切な対策を講ずるよう要求されることがあります。

BSMI statement (Taiwan only)

BSMI statement (Taiwan only)

This is a Class A product based on the standard of the Bureau of Standards, Metrology and Inspection (BSMI) CNS 13438 and CNS 14336–1, Class A.

警告使用者:

這是甲類的資訊產品，在居住的環境中使用時，可能會造成射頻干擾，在這種情況下，使用者會被要求採取某些適當的對策。

Chinese EMI and safety warnings

Voltage:

Risk of injury by electric shock

Before working on this equipment, be aware of good safety practices and the hazards involved with electrical circuits. Use only power cords that have a good grounding path. Ensure that the switch is properly grounded before powering on the unit.

電壓警告:

觸電受傷的危險性

在此設備上進行作業之前，要認知到良好的安全行為和涉及電子電路可能的危害。使用的電源線需有接地路徑。確保供電給設備之前，有適當的接地。

Warning:

Disconnecting the power cord is the only way to turn off power to this device. Always connect the power cord in a location that can be reached quickly and safely in case of emergency.

警告使用者:

斷開電源線，是關閉該設備電源的唯一方法。始終確保連接電源線的位置，在緊急情況下，是可以快速且安全抵達的一個位置。

Electrostatic alert:

Risk of equipment damage

To prevent damage from electrostatic discharge, always wear an antistatic wrist strap connected to an ESD jack when connecting cables or performing maintenance on this device.

⚠ 靜電提醒：

設備損壞的風險

為了防止靜電放電的破壞，在此設備上連接纜線或執行維護時，始終戴上防靜電腕帶並連接到ESD插孔。

MIC notice (Republic of Korea only)

This device has been approved for use in Business applications only per the Class A requirements of the Republic of Korea Ministry of Information and Communications (MIC). This device may not be sold for use in a non-business application.

Observe the Regulatory Marking label on the bottom surface of the chassis for specific certification information pertaining to this model. Each model in the Ethernet Routing Switch 5500 Series which is approved for shipment to/usage in Korea is labeled as such, with all appropriate text and the appropriate MIC reference number.

National safety statements of compliance

EN 60950 statement

This is to certify that the Ethernet Routing Switch 5500 Series equipment is in compliance with the requirements of EN 60950 in accordance with the Low Voltage Directive. Additional national differences for all European Union countries have been evaluated for compliance.

NOM statement (Mexico only)

The following information is provided on the devices described in this document in compliance with the safety requirements of the Norma Oficial Mexicana (NOM):

Exporter:	Avaya Inc. 4655 Great America Parkway Santa Clara CA 95054 USA
Importer:	Avaya Communication de México, S.A. de C.V. Av. Presidente Masarik 111 Piso 6, Col. Chapultepec Morales Deleg. Miguel Hidalgo México D.F. 11570
Input:	Ethernet Routing Switch 5510 / 5530

100 - 240 VAC, 50/60 Hz, 1.3 A max

Ethernet Routing Switch 5520

100 - 240 VAC, 50/60 Hz, 6.5 A max

Información NOM (unicamente para México)

La información siguiente se proporciona en el dispositivo o en los dispositivos descritos en este documento, en cumplimiento con los requisitos de la Norma Oficial Mexicana (NOM):

Exportador: Avaya Inc. 4655 Great America Parkway Santa Clara CA 95054 USA

Importador: Avaya Communication de México, S.A. de C.V.
Av. Presidente Masarik 111
Piso 6, Col. Chapultepec Morales
Deleg. Miguel Hidalgo
México D.F. 11570

Embarcar a: Ethernet Routing Switch 5510 / 5530

100 - 240 VAC, 50/60 Hz, 1.3 A max

Ethernet Routing Switch 5520

100 - 240 VAC, 50/60 Hz, 6.5 A max

Denan statement (Japan/Nippon only)

警告

本製品を安全にご使用頂くため、以下のことにご注意ください。

- 接続ケーブル、電源コード、ACアダプタなどの部品は、必ず製品に同梱されております添付品または指定品をご使用ください。添付品・指定品以外の部品をご使用になると故障や動作不良、火災の原因となることがあります。
- 同梱されております付属の電源コードを他の機器には使用しないでください。上記注意事項を守らないと、死亡や大怪我など人身事故の原因となることがあります。

National Environmental Statements of Compliance

The WEEE Directive 2002/96/EC and RoHS (Restriction of Hazardous Substances) Directive 2002/95/EC sets collection, recycling and recovery targets for various categories of electrical products and their waste.

Restriction on Hazardous Substances Directive Compliance Statement

The Restriction on Hazardous Substances Directive (RoHS) (2002/95/EC), which accompanies the WEEE Directive, bans the use of heavy metals and brominated flame-retardants in the manufacture of electrical and electronic equipment. Specifically, restricted materials under the RoHS Directive are Lead (including solder used in PCB's), Cadmium, Mercury, Hexavalent Chromium, and Bromine.

Avaya declares compliance with the European Union (EU) RoHS Directive (2002/95/EC).

WEEE Directive Compliance Statement



This product at end of life is subject to separate collection and treatment in the EU Member States, Norway, and Switzerland and therefore is marked with the symbol shown at the left. Treatment applied at end of life of these products in these countries shall comply with the applicable national laws implementing Directive 2002/96/EC on Waste of Electrical and Electronic Equipment (WEEE). Avaya declares compliance with the European Union (EU) WEEE Directive (2002/96/EC).

Translations of safety messages

This module contains translations of the safety messages found in the Ethernet Routing Switch 5500 Series documentation suite.

Safety messages

⚠ Caution:

When mounting this device in a rack, do not stack units directly on top of one another in the rack. Each unit must be secured to the rack with appropriate mounting brackets. Mounting brackets are not designed to support multiple units.

! Important:

Achtung: Wenn diese Einheit in einem Rack montiert wird, muß ein gewisser Abstand zur nächsten Einheit gelassen werden. Jede Einheit muß mit geeignetem Befestigungsmaterial gesichert werden. Das Befestigungsmaterial ist nicht für die gleichzeitige Befestigung mehrerer Einheiten geeignet.

! Important:

Si vous installez le module dans une baie, ne l'empilez pas directement sur un autre. Chaque module doit être fixé à sa propre baie à l'aide des supports de montage appropriés. Ces supports ne sont pas conçus pour résister à plusieurs modules.

! Important:

Precaución: Cuando monte este dispositivo en un bastidor, no apile las unidades directamente una encima de otra. Cada unidad debe fijarse en el bastidor con las abrazaderas de montaje adecuadas. Las abrazaderas de montaje no están diseñadas para sostener varias unidades.

! Important:

Se il dispositivo viene installato in un rack, non impilare le unità direttamente una sull'altra. Ogni unità deve essere fissata al rack con le staffe di montaggio appropriate. Le staffe di montaggio non sono state progettate per supportare più unità.



警告: 在机架中安装此设备时, 请勿将多个部件叠放在机架中。必须用合适的安装托架将各个部件固定在机架中。安装托架无法支撑多个部件。



注意: この装置をラックに設置する場合は、ラック内のコネクタを直接積み重ねないようにしてください。各ユニットは専用の取り付けブラケットでラックに固定する必要があります。取り付けブラケットは複数のユニットを支えるようには設計されていません。



注意: 在機箱中掛載此裝置時, 請不要直接在機箱中的另一個裝置上直接堆放裝置。每一裝置都必須使用適當的掛載托架以固定在機架中。掛載托架不能用來支撐多個裝置。

⚠ Caution:

If you are not installing a module in the slot, be sure to keep the metal cover plate in place over the slot. Removing the cover plate impedes airflow and proper cooling of the unit.

! Important:

Achtung: Wenn Sie kein Modul im Schacht verwenden, muß die Metallabdeckung über dem Schacht montiert sein. Eine Entfernung der Abdeckung führt zu einer Verschlechterung der Luftzirkulation und damit zu einer nicht ausreichenden Kühlung der Einheit.

! Important:

Si vous n'installez pas le module dans une baie, veillez à laisser la plaque métallique sur la baie. Si vous la retirez, l'aération du module ne peut pas s'effectuer correctement.

! Important:

Precaution: Si no instala ningún módulo en la ranura, asegúrese de mantener la placa de la cubierta de metal en la misma. Si la retira, impedirá que el aire circule y la unidad se refrigere adecuadamente.

! Important:

Attenzione: Se nello slot non vengono installati moduli, assicurarsi di mantenere la piastra di copertura metallica in sede sopra lo slot. La rimozione della piastra impedisce la ventilazione e il corretto raffreddamento dell'unità.



注意: この装置をラックに設置する場合は、ラック内のユニットを直接積み重ねないようにしてください。各ユニットは専用の取り付けブラケットでラックに固定する必要があります。取り付けブラケットは複数のユニットを支えるようには設計されていません。



注意: スロットにモジュールを取り付けない場合は、スロットにある金属製のカバープレートが外れないように注意してください。カバープレートを動かすと気流が妨げられ、適切なユニット冷却が行われなくなります。



警告: 如果您不打算在该插槽中安装任何模块，请务必使金属盖板正确地盖住该插槽。如果取下盖板，将妨碍通风及部件散热。



注意: 如果您未在插槽中安装模组，請確定金屬殼板正確地蓋在插槽上。移除殼板會阻礙空氣流通以及裝置的適當冷卻度。



警告: 若要關閉此裝置的電源，拔掉插頭是唯一的方法。爲了因應緊急狀況，請將電源線連接到可以快速插拔的地方。

⚠ Warning:

Disconnecting the AC power cord is the only way to turn off AC power to this device. Always connect the AC power cord in a location that can be reached quickly and safely in case of an emergency.

! Important:

Warnung: Das Gerät kann nur durch Ziehen des Netzsteckers ausgeschaltet werden. Schließen Sie das Netzkabel an einer Steckdose an, die in Notfällen schnell und sicher zugänglich ist.

! Important:

Avertissement: Pour mettre le module hors tension, vous devez impérativement déconnecter le cordon d'alimentation. En outre, vous devez dégager un espace minimal dans la zone de câblage pour pouvoir y accéder facilement en cas d'urgence.



警告： 断开交流电源线是切断本设备的交流电源的唯一方法。交流电源线一定要连接到在紧急时刻可以快速安全地接触到的位置。

! Important:

Advertencia: Para apagar el dispositivo debe desenchufar el cable. Conecte siempre el cable de alimentación a una toma segura y de fácil acceso por si se produjera alguna situación de emergencia.

! Important:

Avviso: L'unico modo per disattivare questo dispositivo consiste nello scollegare il cavo di alimentazione. Collegare sempre il cavo di alimentazione ad una presa che sia facilmente e rapidamente accessibile in caso di emergenza.

⚠ Danger:

Use only power cords that have a grounding path. Without a proper ground, a person who touches the switch is in danger of receiving an electrical shock. Lack of a grounding path to the switch may result in excessive emissions.

! Important:

Vorsicht: Verwenden Sie nur Netzkabel mit Schutzerdung. Ohne ordnungsgemäße Schutzerdung besteht für Personen, die den Switch berühren, die Gefahr eines elektrischen Schlages. Eine nichtvorhandene Schutzerdung kann zu sehr starken Abstrahlungen führen.

⚠ Danger:

N'utilisez que des cordons d'alimentation équipés de trajet de mise à la terre. Sans mise à la terre adaptée, vous risquez de recevoir une décharge électrique en touchant le commutateur. Par ailleurs, l'absence de trajet de mise à la terre peut générer des émissions excessives.

! Important:

Peligro: Utilice únicamente cables de alimentación con toma de tierra. De lo contrario, al tocar el interruptor puede recibir una descarga eléctrica. Si no hay un circuito de toma de tierra en el enchufe, puede producirse un exceso de emisiones.

! Important:

Pericolo: Utilizzare esclusivamente cavi di alimentazione dotati di un percorso per la messa a terra. Senza un'adeguata messa a terra, chiunque tocchi lo switch corre il rischio di ricevere una scossa elettrica. L'assenza di un percorso per la messa a terra verso lo switch può comportare un eccesso di emissioni.



危険： 接地経路を持つ電源コードを必ず使用するようになしてください。適切な接地がない状態でスイッチに触ると、感電する危険性があります。また、スイッチへの接地経路がないと、過度な放電を引き起こす可能性があります。



危险： 请仅使用接地的电源线。如果电源线不接地或接地不当，接触交换机的人员可能会受到电击。如果交换机不接地，则可能导致放电过量。

Chapter 3: Introduction

This document provides the information and procedures required to install the hardware, software, cabling, and power for the Ethernet Routing Switch 5000 Series.

Unless otherwise indicated, this information applies to:

- Ethernet Routing Switch 5510-24T
- Ethernet Routing Switch 5510-48T
- Ethernet Routing Switch 5520-24T-PWR
- Ethernet Routing Switch 5520-48-T-PWR
- Ethernet Routing Switch 5530-24TFD
- Ethernet Routing Switch 5632FD
- Ethernet Routing Switch 5650TD
- Ethernet Routing Switch 5650TD-PWR
- Ethernet Routing Switch 5698TFD
- Ethernet Routing Switch 5698TFD-PWR

Navigation

- [Installation fundamentals](#) on page 19
- [Installing the switch](#) on page 45
- [Procedures for installation of the switch](#) on page 57
- [Common procedures](#) on page 93
- [Installation reference](#) on page 95

Chapter 4: Installation fundamentals

The fundamentals topics in this document support the tasks directly associated with installation of the Ethernet Routing Switch 5000 Series.

Electrostatic discharge prevention

This module provides information and procedures for the prevention of electrostatic discharge during the installation process.

Electrostatic discharge (ESD) is a discharge of stored static electricity that can damage equipment and impair electrical circuitry. These electrostatic voltages can result from friction, including, but not exclusive to, pulling cabling through conduits, walking across carpeted areas, and building up of static charge in clothing. ESD damage occurs when electronic components are improperly handled and can result in complete or intermittent failures. While networking equipment is commonly designed and tested to withstand common mode ESD events, voltage sometimes can be discharged to some connector pins but not others, or to some pins before others, which has the potential to damage the networking equipment.

To protect the Avaya Ethernet Routing Switch against ESD damage, take the following preventive measures before connecting any data cables to the device:

- Always use antistatic wrist straps. Make sure the strap is adjusted to provide good skin contact.
- Ensure that work surfaces and equipment racks are properly grounded for protection against electrostatic discharge. The common point must be connected to the building ground wire. In a properly wired building, the nearest reliable ground is typically at the electrical outlet.
- Avoid contact between equipment and clothing. The wrist or ankle strap only protects the equipment from ESD voltages on the body; ESD voltages on clothing can still cause damage.
- Avoid touching any connector pins.
- Do not remove the wrist or ankle strap until the installation is complete.

With new cable installations, Avaya recommends that the use of an ESD discharge cable to reduce the potential for damage from static that can build up in cables. See [Figure 1: ESD cable](#) on page 20.

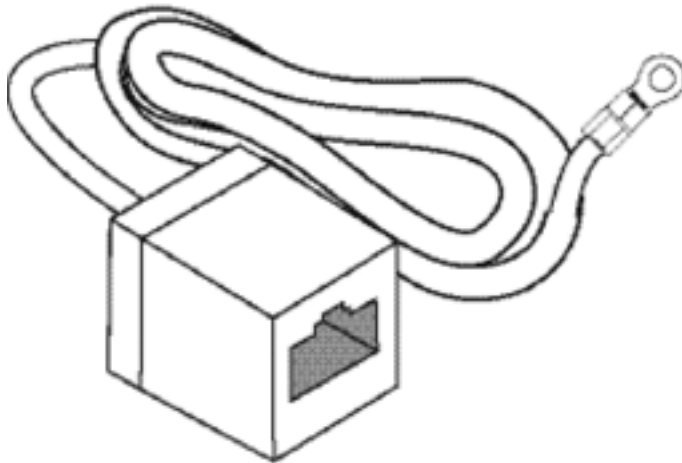

Figure 1: ESD cable

Ethernet Routing Switch 5000 series models

This module describes the 5000 Series switches.

The following table lists the different Ethernet Routing Switch 5000 Series models and the key features for each switch.

Table 1: 5000 Series Switch Platforms

5000 Series Switch Model	Key features
Ethernet Routing Switch 5510-24T	<ul style="list-style-type: none"> • 24 ports • 10/100/1GBase-T • Layer 4 • Diffserv capability • Stackable • Two shared SFP transceiver ports
Ethernet Routing Switch 5510-48T	<p>A 48 port, 10/100/1GBase-T, Layer 4, diffserv-capable, stackable Ethernet switch. This switch contains two shared SFP transceiver ports.</p> <ul style="list-style-type: none"> • 48 ports • 10/100/1GBase-T • Layer 4 • Diffserv capability

5000 Series Switch Model	Key features
	<ul style="list-style-type: none"> • Stackable • Two shared SFP transceiver ports
Ethernet Routing Switch 5520-24T-PWR	<ul style="list-style-type: none"> • 24 ports • 10/100/1GBase-T • Layer 4 • Diffserv capability • Stackable • Power over Ethernet (PoE) capability • Four shared SFP transceiver ports
Ethernet Routing Switch 5520-48T-PWR	<ul style="list-style-type: none"> • 48 ports • 10/100/1GBase-T • Layer 4 • Diffserv capability • Stackable • Power over Ethernet (PoE) capability • Four shared SFP transceiver ports
Ethernet Routing Switch 5530-24TFD	<ul style="list-style-type: none"> • 24 ports • 10/100/1GBase-T • Layer 4 • Diffserv capability • Stackable • Twelve shared SFP transceiver ports • Two XFP transceiver ports
Ethernet Routing Switch 5632FD	<ul style="list-style-type: none"> • 24 fixed 100/1000FX SFP Ethernet ports • Eight 10Gbit XFP ports • Non-PoE • Layer 2/Layer 3 • Stackable Ethernet switch • 1.5 rack units (U) high • Uses modular power supply units and has two field-serviceable power supply receptacles, which support 300W AC or DC power supply modules.

5000 Series Switch Model	Key features
Ethernet Routing Switch 5650TD	<ul style="list-style-type: none"> • 48 port 10/100/1000 Base-T copper Ethernet ports • Two 10Gbit XFP ports • Non-PoE • Layer 2/Layer 3 • Stackable Ethernet switch • 1 rack unit (U) high • Uses modular power supply units and has two field-serviceable power supply receptacles, which support 300W AC or DC power supply modules.
Ethernet Routing Switch 5650TD-PWR	<ul style="list-style-type: none"> • 48 port 10/100/1000 Base-T copper Ethernet ports • Two 10Gbit XFP ports • PoE • Layer 2/Layer 3 • Stackable Ethernet switch • 1 rack unit (U) high • Uses modular power supply units and has two field-serviceable power supply receptacles, which support 600W and 1000W AC or DC power supply modules.
Ethernet Routing Switch 5698TFD	<ul style="list-style-type: none"> • 96 fixed 10/100/1000 Base-T copper Ethernet ports • Six shared ports • Two 10Gbit XFP ports • Non-PoE • Layer 2/Layer 3 • Stackable Ethernet switch • 2 rack units (U) high • Uses modular power supply units and has three field-serviceable power supply receptacles, which support 300W AC or DC power supply modules.
Ethernet Routing Switch 5698TFD-PWR	<ul style="list-style-type: none"> • 96 fixed 100/1000FX SFP Ethernet ports • Six 10Gbit XFP ports

5000 Series Switch Model	Key features
	<ul style="list-style-type: none"> • PoE • Layer 2/Layer 3 • Stackable Ethernet switch • 2 rack units (U) high • Uses modular power supply units and has three field-serviceable power supply receptacles, which support 1000W AC or DC power supply modules.

Common hardware features

The following hardware features are part of all 5000 Series switches:

- Two stack connectors, each operating an aggregate 80 or 144 Gbps
- Mode Select push button (formerly known as UI push button)
- LED display panel
- Console port (DB-9 connector)
- Two 10/100/1000 Mbps copper Ethernet diagnostics ports
- USB 2.0 Type-A port

The following figure shows the front panel of the 5698TFD switch.

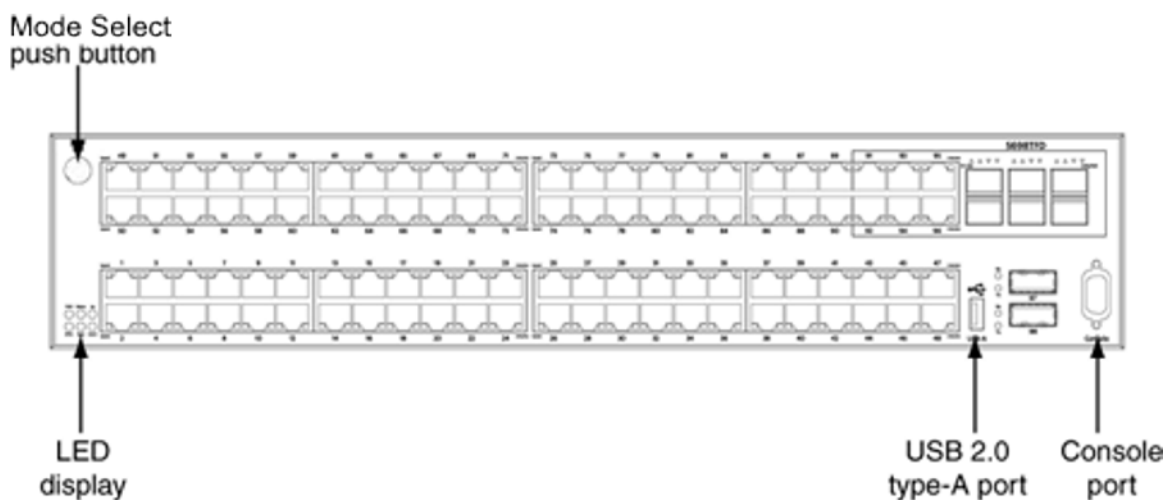

The following figure shows the rear panel of the 5698TFD switch. Not all 5000 Series switches have a USB port on the rear panel. See [Universal Serial Bus ports on the Avaya Ethernet](#)

[Routing Switch 5000 Series](#) on page 24 for information about switches that have the rear-panel USB port.

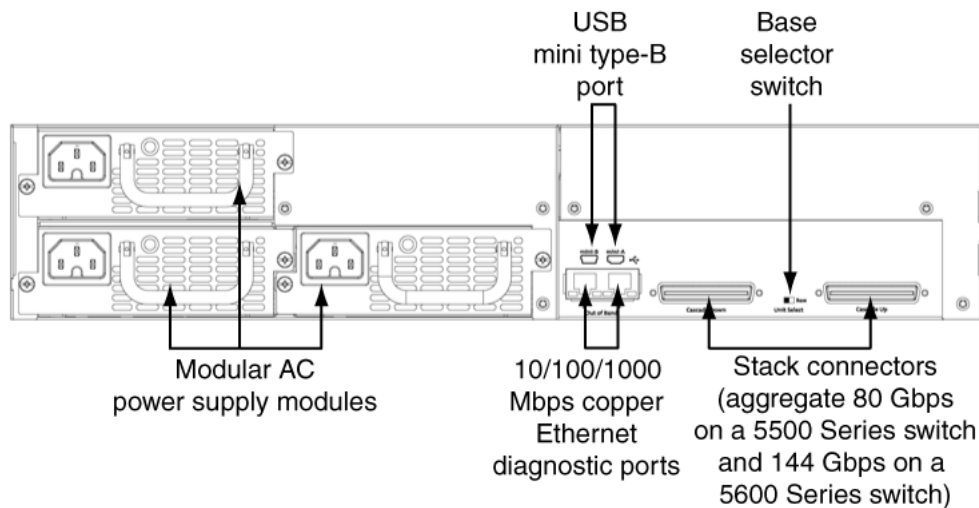

Universal Serial Bus ports on the Avaya Ethernet Routing Switch 5000 Series

The following switches include a Type A USB port on the front panel adjacent to the console port, as well as a rear panel USB port (mini Type B):

- 5530-24TFD
- 5632FD
- 5650TD
- 5650TD-PWR
- 5698TFD
- 5698TFD-PWR

The addition of USB ports will enable switch administrators to perform tasks that were previously completed through TFTP with a commonly available USB Mass Storage Device (also known as a flash drive or thumb drive). These tasks include:

- software download
- syslog backup
- ASCII configuration file generation and download

File and system operations are limited by the size of the USB device in use.

Only USB drives that comply with the Mass Storage sub-section of the USB 1.1 and USB 2.0 specification are supported. Support is not extended to third-party devices that do not comply with these standards. Off-the-shelf drives that do not comply with these standards may not

operate with the 5530-24TFD switch. Consult the documentation provided with the USB drive to ensure compliance with these standards.

! Important:

The USB port on the back panel of the Ethernet Routing Switch 5530-24TFD and Ethernet Routing Switch 5600 Series models is not enabled.

Placement options and cables

The following sections describe the available placement option and requirements, as well as cables for the Ethernet Routing Switch 5000 Series switch.

Environmental requirements

This module describes the environmental requirements for the Ethernet Routing switches.

The Ethernet Routing switches must be properly mounted in a dry, well-ventilated area with adequate power available for optimum operation. See the environmental specifications in [Table 8: Job aid: Ethernet Routing Switch 5500 Series environmental requirements](#) on page 58.

Placement options

You can mount 5000 Series switches on a flat surface such as a table or shelf, or in a rack. Choose the mounting option that best suits your location. The following sections describe the options.

Navigation

- [Switch installation on a table or shelf](#) on page 25
- [Switch installation on the wall](#) on page 26
- [Switch installation in an equipment rack, front mount option](#) on page 26
- [Switch installation in an equipment rack, rear mount option](#) on page 26

Choose the mounting solution that suits your requirements and site.

Switch installation on a table or shelf

You can mount 5000 Series switch on a flat surface such as a table or shelf. See [Mounting on a table or shelf](#) on page 62, to install a single unit on a table or shelf.

The surface, whether a shelf or table, must be able to support the combined weight of the switch and attached cables; between 15 and 20 pounds (7 to 9 kilograms) for a 5500 Series switch, and between 21 and 33 pounds (9.5 to 15 kilograms) for a 5600 Series switch.

⚠ Caution:

Do not place an Ethernet Power Supply Unit 10 or Ethernet Redundant Power Supply 15 on top of an Ethernet Routing Switch 5500 Series. The switch housing of a 5500 Series Ethernet Routing Switch is not strong enough to support the weight of these units.

Switch installation on the wall

You can mount 5000 Series switches on a wall. See [Mounting on a wall](#) on page 64, to mount the switch on a wall.

Do not install a switch on a wall if the switch has a height greater than 1 rack unit (U).

Switch installation in an equipment rack, front mount option

You can mount 5000 Series switches in a rack with the front panel at the front of the rack. See [Installing a front mounted switch in an equipment rack](#) on page 66, to install the switch in a rack.

Before you begin this procedure, ensure that the equipment rack meets the following requirements:

- A space equivalent to the rack height of the switch is provided for each switch in an EIA or IEC standard 19-inch (48.2 centimeter) or TIA 23-inch (58.4 centimeter) equipment rack.
- The rack is bolted to the floor and braced if necessary.
- The rack is grounded to the same grounding electrode used by the power service in the area. The ground path must be permanent and must not exceed 1 ohm of resistance from the rack to the grounding electrode.

⚠ Caution:

When you mount the switch in a rack, do not stack units directly on top of one another in the rack. Each unit must be secured to the rack with the appropriate mounting brackets. Mounting brackets are not designed to support multiple units.

Switch installation in an equipment rack, rear mount option

You can mount 5000 Series switches in a rack with the rear panel at the front of the rack. See [Installing a rear mounted switch in an equipment rack](#) on page 68, to install the switch in a rack.

Before you begin this procedure, ensure that the equipment rack meets these requirements:

- A space equivalent to the rack height of the switch is provided for each switch in an EIA or IEC standard 19-inch (48.2 centimeter) or TIA 23-inch (58.4 centimeter) equipment rack.
- The rack is bolted to the floor and braced if necessary.
- The rack is grounded to the same grounding electrode used by the power service in the area. The ground path must be permanent and must not exceed 1 ohm of resistance from the rack to the grounding electrode.

⚠ Caution:

When you mount the switch in a rack, do not stack units directly on top of one another in the rack. Each unit must be secured to the rack with the appropriate mounting brackets. Mounting brackets are not designed to support multiple units.

Single and multiple switch arrangements

This module describes standalone and stacked arrangements.

Navigation

- [Standalone arrangement](#) on page 27
- [Stack arrangement](#) on page 27

You can stack any of the 5000 Series switches. You can connect up to eight 5500 Series devices in a stack to provide uninterrupted connectivity for up to 384 ports. This stack is managed as a single unit.

You can connect up to 8 5600 Series devices in a stack to provide uninterrupted connectivity for up to 384 ports. Bandwidth in a 5600 Series stack is 144 Gbps.

You can connect a combination of 5500 and 5600 Series switches in a stack of up to eight devices (this is called a hybrid stack). Bandwidth in a hybrid stack is 80 Gbps.

Standalone arrangement

This module describes a standalone configuration.

Any one switch can operate in a standalone configuration. You can add more switches as your traffic increases.

Stack arrangement

This module describes a stack arrangement.

Navigation

- [Cascade down](#) on page 30
- [Cascade up](#) on page 31
- [Redundant cascade stacking](#) on page 32

You connect the switches in the stack by the stack connectors. You designate one unit as the base unit by setting a switch on the back panel.

The stack connector is a component of the Ethernet Routing Switch 5500 Series back panel and consists of the Unit Select switch, Cascade Down connector, and Cascade Up connector.

The Cascade Down connector connects this switch to the next unit in the stack through a cascade cable. A connection from this connector must be attached to the Cascade Up connector of the next switch in the stack. A return cable from another Cascade Down connector to this unit's Cascade Up connector completes the stack connection.

! Important:

To create a stack connection, order the appropriate Ethernet Routing Switch 5000 Series cascade cables to ensure fail-safe stacking. An 18 inch cable is provided with the switch. Ensure you order additional stacking cables of the correct length for a stack of three or more units -- you require one long cable (stack return cable) to complete the loop in a stack from the bottom unit to the top unit. See [Cascade down](#) on page 30 and [Cascade up](#) on page 31.

The Cascade Up connector provides an attachment point for accepting a cascade cable connection from another unit in the stack. A return cable from the Cascade Down connector to the Cascade Up connector on the adjacent unit completes the stack connection.

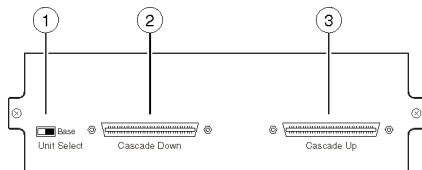

- 1 = Unit select switch
- 2 = Cascade down connector
- 3 = Cascade up connector

Figure 2: Stack connector for a 5500 Series switch

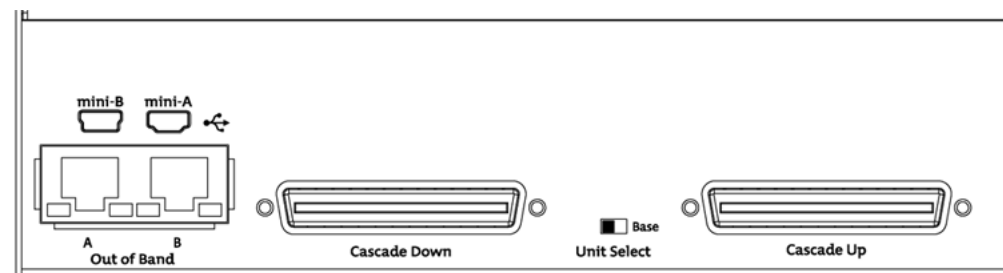

Figure 3: Stack connector for a 5600 Series switch

Understanding stack types

This module describes the different stack types.

Due to stack parameters being associated with the base unit, the physical stack order depends on the base unit position and whether the stack is configured cascade up (stack up) or cascade down (stack down). This designation depends on the stack cabling arrangement.

The Unit Select switch is used to designate a switch in the stack as a base or non-base unit. Sliding the switch to the right designates that switch as the base unit. Only one switch in a stack may have the Unit Select switch in the base unit position. All other switches in the stack must have the Unit Select switch in the left position which designates them as non-base units.

During the initial installation of the stack, the software automatically determines the physical order of all units in the stack according to the position of the base unit within the stack. Thereafter, the individual units maintain their original unit numbering, even if the position of one or more units in the stack is changed.

For example, when the stack is initially powered, the base unit becomes unit 1 and the unit that the base unit connects to (via the Cascade Down cable) becomes unit 2 (and the next unit is unit 3 and so on), until the maximum stack configuration (up to 8 units for a 5500 Series stack or a hybrid stack; up to 8 units for a pure 5600 Series stack) is reached. If the base unit is changed to another unit in the stack, the new base unit keeps its original unit number in the stack.

When a switch participates in a stack configuration, a stack MAC address is automatically assigned during stack initialization. The stack MAC address is the base unit MAC address plus 1. If another unit in the stack is assigned as the base unit, the new stack MAC address is the MAC address of the new base unit plus 1. The original stack IP address still applies to the new base unit.

If an assigned base unit fails, the next unit in the stack order automatically becomes the new temporary base unit. This change is indicated by the Base LED on the temporary base unit LED display panel moving to a steady amber state.

This automatic failover is a temporary safeguard only. If the stack configuration loses power, the temporary base unit will not power up as the base unit when power is restored. Also, if the original unit rejoins the stack, it will not resume base unit status. For this reason, always assign the temporary base unit as the base unit until the failed unit is repaired or replaced.

! Important:

If the temporary base unit is not assigned as the new base unit, and the temporary base unit fails, the next unit in the stack order becomes the temporary base unit. This process will continue after successive failures until only two units are left in the stack.

Regardless of stack configuration, the following applies:

- When power is applied to the stack the base unit initializes, typically within sixty seconds, and the entire stack powers up as a single logical unit.
- A RS-232 communications cable can be attached to the console port of any switch in the stack to establish a console connection.
- A software upgrade can be performed on the stack from any switch using the console interface, a Telnet session, the Enterprise Device Manager interface, or any SNMP-based management software.
- The stack can be managed using a Telnet session, Enterprise Device Manager interface, or any SNMP-based management software through any stack switch port.

Cascade down

The system automatically numbers the physical units based on the designated base unit (Unit 1). In a cascade down configuration, the base unit is physically located as the top unit in the stack. The cable connected to the Cascade Down connector of the base unit terminates in the Cascade Up connector on the next unit in the stack which is physically located below the base unit. This next unit is designated Unit 2. The stack is wired downward through the units and the system continues to number in this manner throughout the stack. In this configuration, the base unit discovers the stack in a cascade down (stack down) direction. The following illustration shows a cascade down (stack down) configuration.

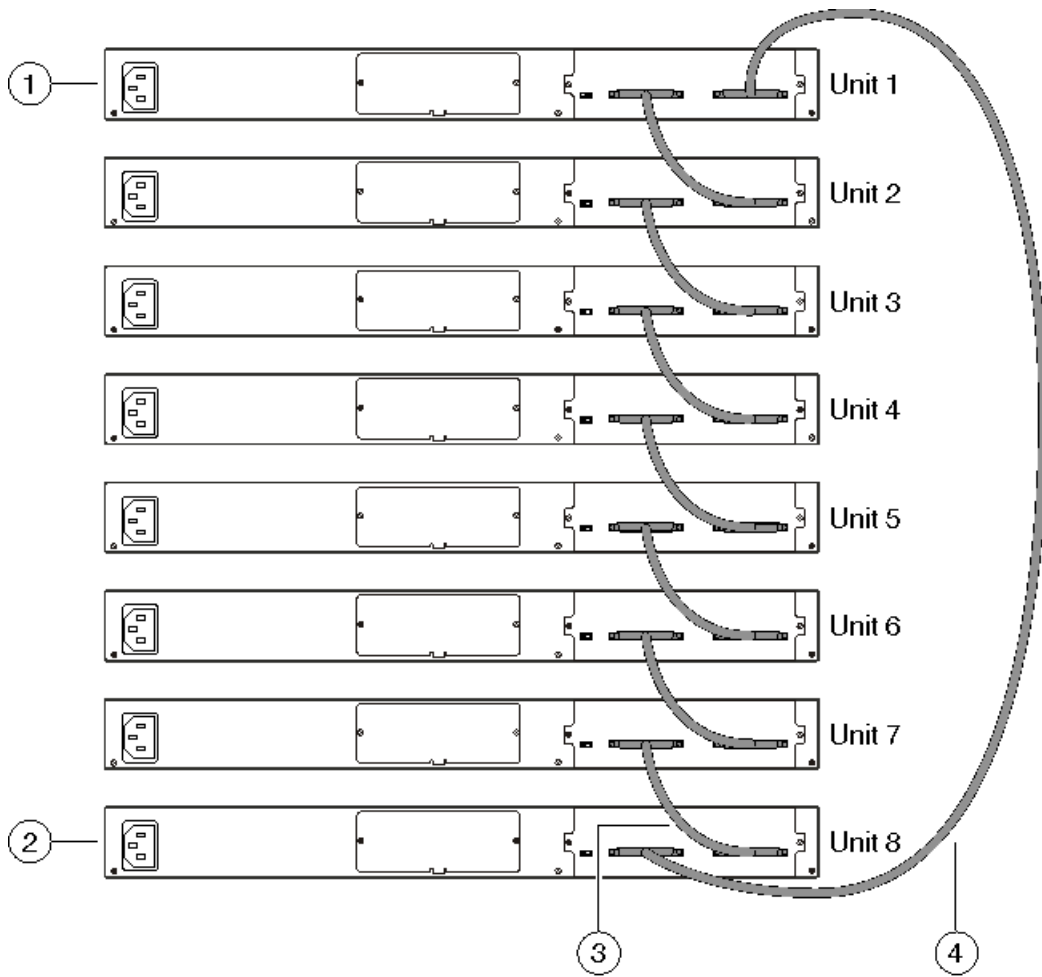

Figure 4: Cascade down configuration

! Important:

Since many network management software packages assume a cascade down (stack down) configuration, Avaya recommends the usage of this configuration.

For stack installation procedures, see [Stack configuration](#) on page 85.

Cascade up

In a cascade up (stack up) configuration, the base unit is physically located as the top unit in the stack. The cable connected to the Cascade Down connector of the base unit terminates in the Cascade Up connector physically located at the bottom of the stack. This next unit is designated Unit 2. The stack is wired upward through the units and the system continues to number in this manner throughout the stack. In this configuration, the base unit discovers the

stack in a cascade up (stack up) direction. The following illustration shows a cascade up (stack up) configuration.

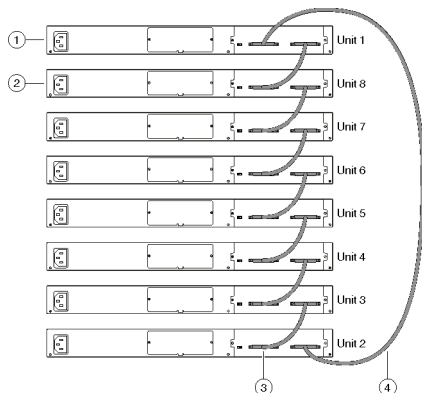

Figure 5: Cascade up configuration

For stack installation procedures, see [Stack configuration](#) on page 85.

Redundant cascade stacking

The 5000 Series switches allow a stack of up to 8 units in a pure 5600 Series stack, a 5500 Series, or hybrid stack into a dual-path cascade stack. If any single unit fails or if a cable is accidentally disconnected, other units in the stack remain operational without interruption.

In addition to increasing bandwidth, the software uses the cables to provide two paths between units. If one path breaks the data travels over the remaining path with half the normal inter-switch bandwidth.

The following diagram shows an example of how a stack configuration reacts to a failed connection in the stack configuration. In the illustrated example, the following occurs:

- Unit 3 becomes non-operational due to a unit failure, cable disconnection, or a loss of power.
- Units 2 and 4, directly upstream and downstream from Unit 3, sense the loss of link signals from unit 3. The software causes all the data to traverse the remaining path.
- The Cascade Down LED for Unit 2 and the Cascade Up LED for Unit 4 turn amber to indicate an error has been detected.
- The remaining stack units continue to be connected.

There are 4 internal ports for two Cascade links. Internal ports 1 and 2 are associated with Cascade-Down link and internal ports 3 and 4 are associated with Cascade-Up link. When

viewing the event log after a stack port goes down, use the following information to help determine the problem:

- Message Stack port 1 DOWN or Stack port 2 DOWN means Cascade-Down link is down.
- Message Stack port 1 UP or Stack port 2 UP means Cascade-Down link is up.
- Message Stack port 3 DOWN or Stack port 4 DOWN means Cascade-Up link is down.
- Message Stack port 3 UP or Stack port 4 UP means Cascade-Up link is up.

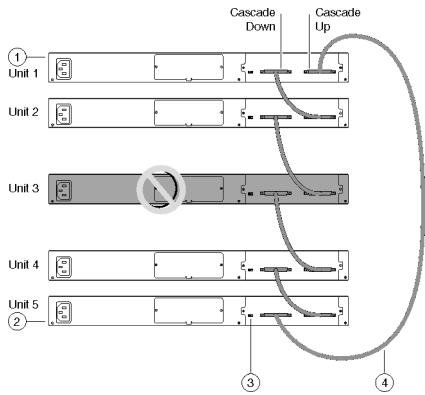

Figure 6: Redundant stack configuration

For stack installation procedures, see [Stack configuration](#) on page 85.

Identifying cables to use with the Ethernet Routing Switch

The following table lists the required cables for a 5000 Series switch and cable specifications.

Table 2: Switch cabling requirements

Required cable	Description
10/100/1GBase-T Ports	The interconnect cabling must conform to the Cat5e, Cat6, or Cat6e specification of the Commercial Building Telecommunications Cabling Standard, ANSI/TIA/EIA 568-B fitted with an RJ-45 Module Jack.
Console Port	Serial cable with a DB-9 female connector on both ends. The maximum length for the console port cable is 25 feet (8.3 meters).
Shared SFP Transceiver Ports	Varies with the installed SFP Transceiver. Refer to the documentation that was shipped with the SFP Transceiver for specifications.

Required cable	Description
XFP Transceiver Ports	Varies with the installed XFP Transceiver. Refer to the documentation that was shipped with the XFP Transceiver for specifications.
USB Ports	USB 2.0 compliant cable with a USB Type A connector on both ends.

! Important:

In Autonegotiation mode, the Ethernet Routing Switch 5000 Series switches automatically provide the proper MDI/MDI-X connection on the RJ-45 ports; thereby eliminating the need for crossover cables. When Autonegotiation is disabled on 10/100 ports, they are configured as an MDI-X connection.

Connecting a transceiver to the switch or switch stack

The following sections describe small form factor pluggable (SFP) transceivers in the Ethernet Routing Switch 5500 Series. For installation and removal procedures, see *Avaya Ethernet Routing Switch 5000 Series Installation — SFPs and XFPs - (NN47200-302)*.

Navigation

[Understanding transceiver connections](#) on page 34

Understanding transceiver connections

The following sections describe transceiver connections.

Small form factor pluggable (SFP) transceivers interface a device motherboard to a fiber optic or unshielded twisted pair network cable. The SFPs described in this section provide Ethernet at 1 gigabit per second (Gbit/s).

Select the appropriate transceiver to provide the required reach. SFPs are available for cable distances of up to 100 meters (m), 550 m, 10 kilometers (km), 40 km, 70 km, and 120 km. Any reach over 100 m requires fiber optic cable.

SFPs are hot-swappable input/output enhancement components designed for use with Avaya products to allow Gigabit Ethernet ports to link with other Gigabit Ethernet ports over various media types.

The following table lists SFP and XFP models.

Table 3: SFPs and XFPs

SFP model	Description	Part Number
1000Base-SX SFP	850 nm LC connector	AA1419013-E5
1000Base-SX SFP	850 nm MT-RJ connector	AA1419014-E5
1000Base-LX SFP	1310 nm LC connector	AA1419015-E5
1000BaseCWDM-XD SFP	1470 nm LC connector, up to 40 km	AA1419025-E5
1000BaseCWDM-XD SFP	1490 nm LC connector, up to 40 km	AA1419026-E5
1000BaseCWDM-XD SFP	1510 nm LC connector, up to 40 km	AA1419027-E5
1000BaseCWDM-XD SFP	1530 nm LC connector, up to 40 km	AA1419028-E5
1000BaseCWDM-XD SFP	1550 nm LC connector, up to 40 km	AA1419029-E5
1000BaseCWDM-XD SFP	1570 nm LC connector, up to 40 km	AA1419030-E5
1000BaseCWDM-XD SFP	1590 nm LC connector, up to 40 km	AA1419031-E5
1000BaseCWDM-XD SFP	1610 nm LC connector, up to 40 km	AA1419032-E5
1000BaseCWDM-ZX SFP	1470 nm LC connector, up to 70 km	AA1419033-E5
1000BaseCWDM-ZX SFP	1490 nm LC connector, up to 70 km	AA1419034-E5
1000BaseCWDM-ZX SFP	1510 nm LC connector, up to 70 km	AA1419035-E5
1000BaseCWDM-ZX SFP	1530 nm LC connector, up to 70 km	AA1419036-E5
1000BaseCWDM-ZX SFP	1550 nm LC connector, up to 70 km	AA1419037-E5
1000BaseCWDM-ZX SFP	1590 nm LC connector, up to 70 km	AA1419039-E5
1000BaseCWDM-ZX SFP	1610 nm LC connector, up to 70 km	AA1419040-E5

SFP model	Description	Part Number
1000Base-T SFP	Category 5 copper unshielded twisted pair (UTP), RJ-45 connector	AA1419043-E5
1000Base-SX DDI SFP	850 nm DDI LC connector	AA1419048-E5
1000Base-LX DDI SFP	1310 nm DDI LC connector	AA1419049-E5
1000BASE-BX bidirectional SFP	1310 nm, single fiber LC (Must be paired with AA1419070-E5)	AA1419069-E5
1000BASE-BX bidirectional SFP	1490 nm, single fiber LC (Must be paired with AA1419069-E5)	AA1419070-E5
100Base-FX SFP	1310 nm LC connector NOTE: Supported on the 5600 Series switches only.	AA1419074-E6
XFP Model	Description	Part Number
10GBase-LR/LW XFP	1-port 1310 nm SMF, LC connector	AA1403001-E5
10GBASE-ER/EW	1-port 40km, 1550nm SMF, LC connector	AA1403003-E5
10GBase-SR XFP	1-port 850 nm MMF, LC connector	AA1403005-E5
10GBase-ZR/ZW XFP	1550 nm SMF LC connector	AA1403006-E5
10GBase-LRM XFP	1310 nm, up to 220 m over MMF, DDI	AA1403007-E6

See *Avaya Ethernet Routing Switch 5000 Series Installation — SFPs and XFPs - (NN47200-302)* for a list of supported SFPs and your latest product-specific release notes. Information contained in the Release Notes takes precedence over any information contained in this document.

Preparing for power requirements of the switch

Navigation

- [Avaya Ethernet Routing Switch 5510-24T and 5510-48T](#) on page 37
- [Avaya Ethernet Routing Switch 5520-24T-PWR and 5520-48T-PWR](#) on page 37

- [Avaya Ethernet Routing Switch 5530-24TFD](#) on page 38
- [Avaya Ethernet Power Supply 10](#) on page 39
- [Avaya Ethernet Redundant Power Supply 15](#) on page 39
- [Avaya Ethernet DC-DC converter module](#) on page 39

Avaya Ethernet Routing Switch 5510-24T and 5510-48T

This section details the power requirements of the Avaya Ethernet Routing Switch 5510-24T and 5510-48T.

The following table lists the power specifications for the Ethernet Routing Switch 5510.

Table 4: AC power specifications

Input Current	1.3 to 0.65A
Input Voltage (rms)	100 to 240 VAC at 47 to 63 Hz
Power Consumption	135 W
Thermal Rating	460 BTU/Hr maximum

Avaya Ethernet Routing Switch 5520-24T-PWR and 5520-48T-PWR

This section details the power requirements of the Avaya Ethernet Routing Switch 5520-24T-PWR and 5520-48T-PWR.

The following table lists the power specifications for the Ethernet Routing Switch 5520-24T-PWR and 5520-48T-PWR.

Table 5: AC power specifications

Input Current	6.5 A at 115 VAC or 3.25 A at 230 VAC
Input Voltage (rms)	100 to 240 VAC 50/60 Hz
Power Consumption	600 W maximum
Thermal Rating	850 BTU/Hr
Inrush Current	20 A 120 VAC at maximum load, 40 A 240 VAC at maximum load
Turn on Condition	1 second maximum after application of AC power.

	<p>! Important: 12 V output rise time, from 10 percent to 90 percent, shall be a maximum of 50 ms and monotonic under all defined input and output conditions.</p>
Efficiency	70 percent minimum

Avaya Ethernet Routing Switch 5530-24TFD

This section details the power requirements of the Avaya Ethernet Routing Switch 5530-24TFD.

The following table lists the power specifications for the Ethernet Routing Switch 5530-24TFD.

Table 6: AC power specifications

Input current	1.7 A at 120 VAC or 0.85 A at 240 VAC
Input voltage (rms)	100 to 240 VAC 50/60 Hz
Typical power consumption	125 W
Typical thermal rating	427 BTU/Hr
Maximum power consumption	150W
Maximum thermal rating	512 BTU/Hr
Inrush current	20 A 120 VAC at maximum load, 40 A 240 VAC at maximum load
Turn on condition	1 second maximum after application of AC power. ! Important: 12 V output rise time, from 10 percent to 90 percent, shall be a maximum of 50 ms and monotonic under all defined input and output conditions.
Efficiency	70 percent minimum

5500 Series power options

This section describes the available power options for Ethernet Routing Switch 5500 Series switches.

Avaya Ethernet Power Supply 10

This module describes the Avaya Ethernet Power Supply 10.

The Ethernet Power Supply 10 is a DC power supply used with the AC power supply to provide DTE power to all of the PoE ports.

Output Current	4.2 A maximum
Output Voltage	-48 VDC
Output Power	200 W maximum

Avaya Ethernet Redundant Power Supply 15

This module describes the Avaya Ethernet Redundant Power Supply 15 (RPS 15).

The RPS 15 is a DC power supply used with the AC power supply to provide DTE power to all of the PoE ports in the Avaya Ethernet Routing Switch 5520.

Input Voltage	100 to 240 VAC 50/60 Hz
Input Current	10A maximum
Inrush Current:	40A maximum (regardless of ambient temperature)
Output Voltage	47.5 VDC
Output Current	12.0 A
Output Power	600 W

Avaya Ethernet DC-DC converter module

This module describes the Avaya Ethernet DC-DC converter module.

The Ethernet Routing Switch 5510 requires an additional DC-DC converter module to use the RPS 15. This module connects the RPS 15 to the ERS 5510 but is not required for other switches in the 5500 Series. For information on connecting this module to the ERS 5510, see DC-DC Converter Module for the Baystack 5000 Series Switch, 215081-A.

Internal power source only option

This module describes the internal power source only option.

Using the Avaya Ethernet Routing Switch 5520-PWR switch and its internal power source only option, you have a total of 320 watts of available power. You can power up to 48 ports at 6.6 W for each port with this configuration or 20 ports at the maximum power of 15.4 W for each port.

External power source only option

This module describes the external power source only option.

Using the Avaya Ethernet Routing Switch 5520-PWR switch and its external power source the only option (Avaya Ethernet Redundant Power Supply Unit 15) you have is a total of 320 watts of available power. You can power up to 48 ports at 6.6 W for each port with this configuration or 20 ports at the maximum power of 15.4 W for each port.

Power sharing option

This module describes the power sharing option.

Using the Avaya Ethernet Routing Switch 5520-PWR switch and the Avaya Ethernet 15 RPSU as an external power source with the power sharing configuration supplies 740W to the Avaya Ethernet Routing Switch 5520-PWR. This enables all 48 ports to supply the Max power of 15.4W for each port.

Power supply unit (PSU) option

This module describes the power supply unit option.

An external power source (Avaya Redundant Power Supply 15 (Avaya RPS 15)) can provide redundant power to the Avaya Ethernet Routing Switch 5520. That is, the power fails over to the Avaya RPS 15 in case there is a problem with the switch's internal power.

If the Avaya Ethernet Routing Switch 5520 is supplying 320 watts of power to Powered Devices and the supply to the internal power source is interrupted, the power to all powered devices is uninterrupted due to failover to the Avaya RPS 15.

By using the Avaya RPS 15, you have a total of 320W of PoE redundant power, which enables up to 48 ports to be powered at 6.6W.

5600 Series power options

The Ethernet Routing Switch 5600 Series uses power supply modules. All 5600 Series power supply modules have an internal fuse for protection. The 5600 Series power contain fans for cooling purposes.

Two power supply modules can operate in parallel for redundancy. In the case of the 5698 model, 3 power supply modules can be used to provide true N+1 redundancy. For information about which power supply modules you can install in each 5600 Series switch, and how many, see [Power supply module installation matrix](#) on page 42

All 5600 Series power supply modules are hot-swappable and hot-pluggable.

AC and DC power specifications

The following table describes the AC and DC power specifications for the Ethernet Routing Switch 5600 Series.

Model	Input current Amps maximum per power supply			Power consumption	Thermal rating	Power supply used	Power over Ethernet (PoE)
	100-120 VAC	48 VDC	200-240 VAC	Watts maximum	BTU/h maximum	Watts AC/DC, DC/DC	Power per port (Watts)
ERS 5632FD	1.8		0.9	190	650	300	n/a
ERS 5632FD DC		4.2		190	650	300	n/a
ERS 5650TD	1.2		0.6	132	450	300	n/a
ERS 5650TD DC		3.0		132	450	300	n/a
ERS 5650TD-PWR	5.5		2.75	218	745	600	7.7
ERS 5650TD-PWR	10.5		5.25	290	990	1000	15.4

Model	Input current Amps maximum per power supply			Power consumption	Thermal rating	Power supply used	Power over Ethernet (PoE)
	100-120 VAC	48 VDC	200-240 VAC	Watts maximum	BTU/h maximum	Watts AC/DC, DC/DC	Power per port (Watts)
ERS 5650 TD-PWR (2 power supplies)	5.3 *		2.65 *	290	990	600 *	15.4
ERS 5650 TD-PWR DC		21		290	990	1000	15.4
ERS 5698TFD	2.0		1.0	215	735	300	n/a
ERS 5698TFD DC		4.5		215	735	300	n/a
ERS 5698TFD -PWR	10.5		5.25	400	1365	1000	7.7
ERS 5698TFD -PWR (2 power supplies)	9.5 *		4.75 *	545	1850	1000 *	15.4
ERS 5698TFD -PWR DC		26		400	1365	1000	7.7
ERS 5698TFD -PWR DC (2 power supplies)		21 *		545	1850	1000 *	15.4
* per power supply							

Power supply module installation matrix

The following table indicates the type and maximum number of power supply modules that you can use with each 5600 Series switch. If you install two or more power supply modules in one switch, the power supply modules must be identical wattage.

Power Supply Module	5632 - FD	5632 - FD DC	5650 - TD	5650 - TD DC	5650 - TD PWR	5650 - TD PWR DC	5698 - TFD	5698 - TFD DC	5698 - TFD PWR	5698 - TFD PWR DC
300W AC/DC	2		2				3			
300W DC/DC		2		2				3		
600W AC/DC					2					
1000 W AC/DC					2				3	
1000 W DC/DC						2				3

For regulatory information about the power supply modules, see *Avaya Ethernet Routing Switch 5600 Series — Regulatory Information (NN47201-101)*.

PoE capabilities for 5600 Series switch ports

The PoE capability at each 5600 Series switch port is dependant on the power supply modules that you install. The following table shows the PoE capability at each port as a function of the power supply module installed.

Table 7: PoE capability matrix

	5650TD-PWR		5698TFD-PWR
10/100/1000 TX Ports 100FE/1GE SFP Ports 10GFX XFP Ports	48 0 2	48 0 2	96 6 2
Main power	600W	1000W	2 x 1000W
Redundant power	600W	1000W	1000W
PoE power at each port	7.7W	15.4W	15.4W

Ordering the phone dongle

This module describes the phone dongle and how you use it.

The part number for the Avaya Ethernet Routing Switch 5520 (5520-24T/48T-PWR) universal phone dongle is DY4311046.

Chapter 5: Installing the switch

About this task

Installation of hardware and software introduces the Avaya Ethernet Routing Switch 5000 Series to the network. Installation tasks include the procedures required to bring the switch online. The procedures reflect the recommended method to install the 5000 Series switch in the simplest way, with necessary safety precautions. Installation does not include customized configuration, switch maintenance, or switch administration.

Prerequisites:

- [Environmental requirements](#) on page 25
- [Placement options](#) on page 25
- [Standalone arrangement](#) on page 27
- [Single and multiple switch arrangements](#) on page 27
- [Stack arrangement](#) on page 27
- [Understanding stack types](#) on page 29
- [Understanding transceiver connections](#) on page 34
- [Avaya Ethernet Redundant Power Supply 15](#) on page 39
- [Avaya Ethernet DC-DC converter module](#) on page 39

Installation navigation:

- [Installation tasks](#) on page 45

Installation tasks

This work flow shows you the sequence of tasks you perform to install the switch.

Installation Tasks Task Flow

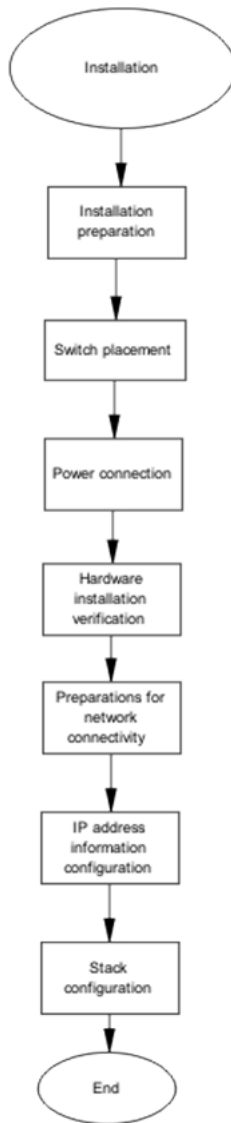

Navigation:

- [Installation Preparation](#) on page 47
- [Switch placement](#) on page 47
- [Power connection](#) on page 48
- [Hardware installation verification](#) on page 49
- [Preparations for network connectivity](#) on page 50

- [IP address information configuration](#) on page 51
- [Stack configuration](#) on page 53

Installation Preparation

This task flow shows the sequence of procedures you perform to prepare for ERS 5500 installation.

Installation Preparation Task Flow



Navigation:

- [Installation preparation](#) on page 57
- [Verifying environment suitability](#) on page 57
- [Verifying the contents of the box](#) on page 60

Switch placement

This task flow shows the sequence of procedures you perform to place the switch.

Switch Placement Task Flow

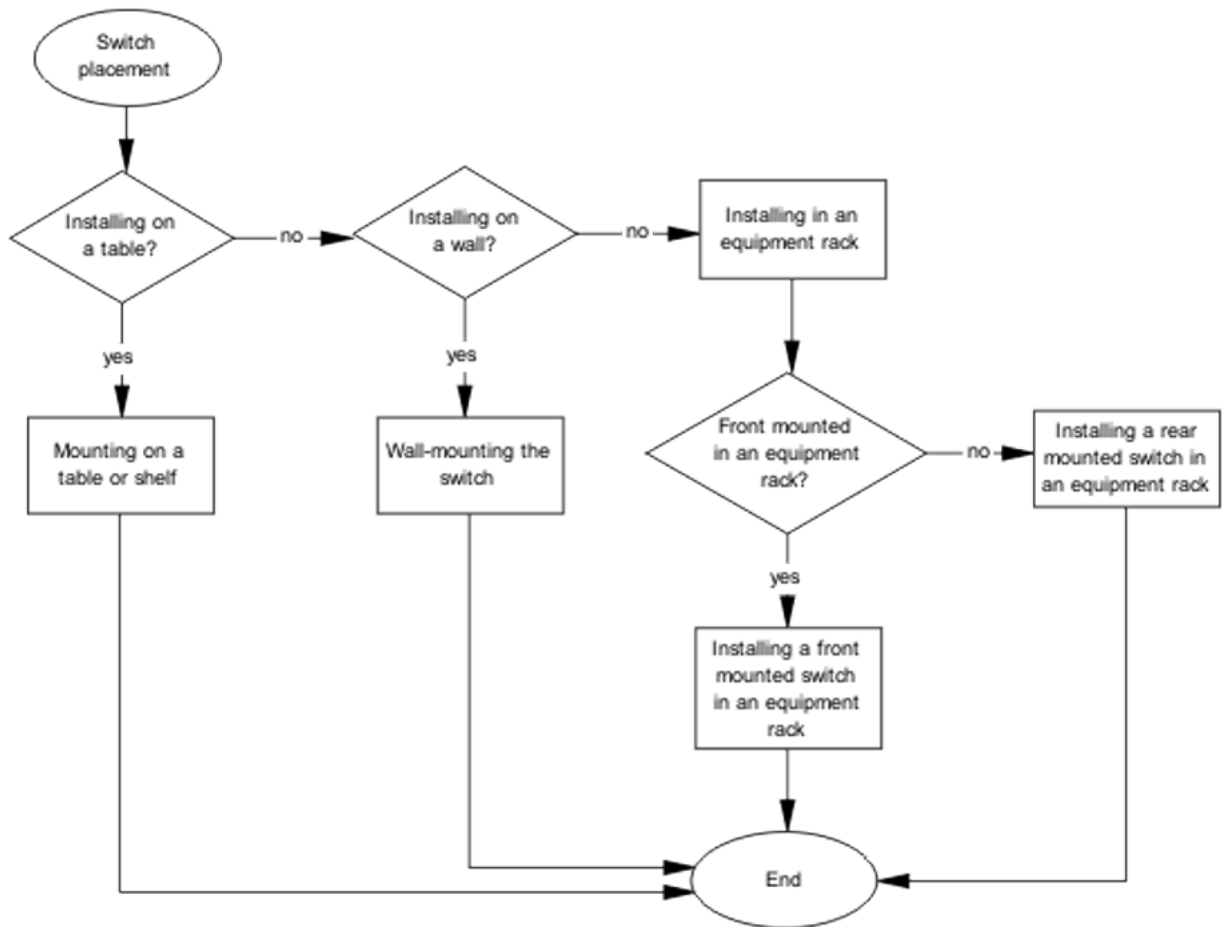

Navigation:

- [Mounting on a table or shelf](#) on page 62
- [Mounting on a wall](#) on page 64
- [Installing a front mounted switch in an equipment rack](#) on page 66
- [Installing a rear mounted switch in an equipment rack](#) on page 68

Power connection

This task flow shows the sequence of procedures you perform to connect power.

Power Connection Task Flow

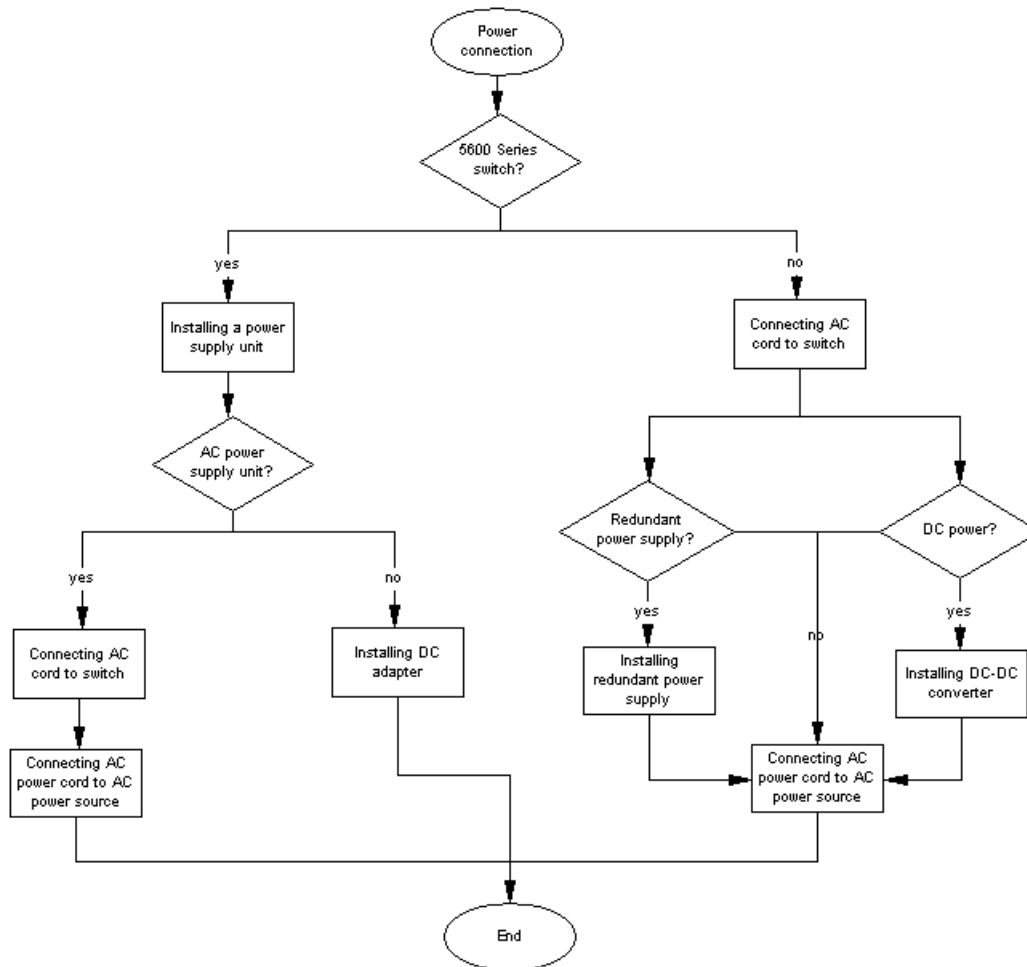

Navigation:

- [Connecting an AC cord to switch](#) on page 72
- [Installing a redundant power supply in a 5500 Series switch](#) on page 73
- [Installing DC-DC converter in a 5500 Series switch](#) on page 74

Hardware installation verification

Use the following procedures to install the hardware.

Hardware Installation Verification Task Flow

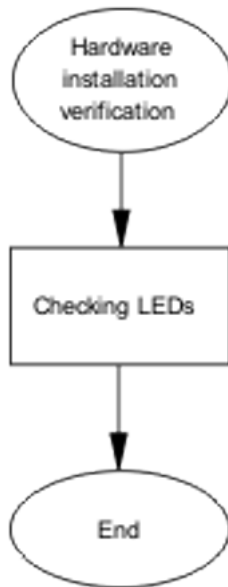

Navigation:

- [Checking LEDs](#) on page 75

Preparations for network connectivity

Use the following procedures to prepare for network connectivity.

Preparations for Network Connectivity Task Flow

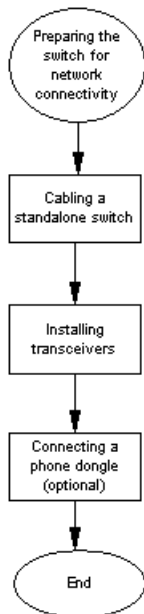
**Navigation:**

- [Cabling a standalone switch](#) on page 79
- [Installing transceivers](#) on page 80
- Connecting a phone dongle

IP address information configuration

This task flow shows the sequence of procedures you perform to configure IP address information.

IP Address Information Configuration Task Flow

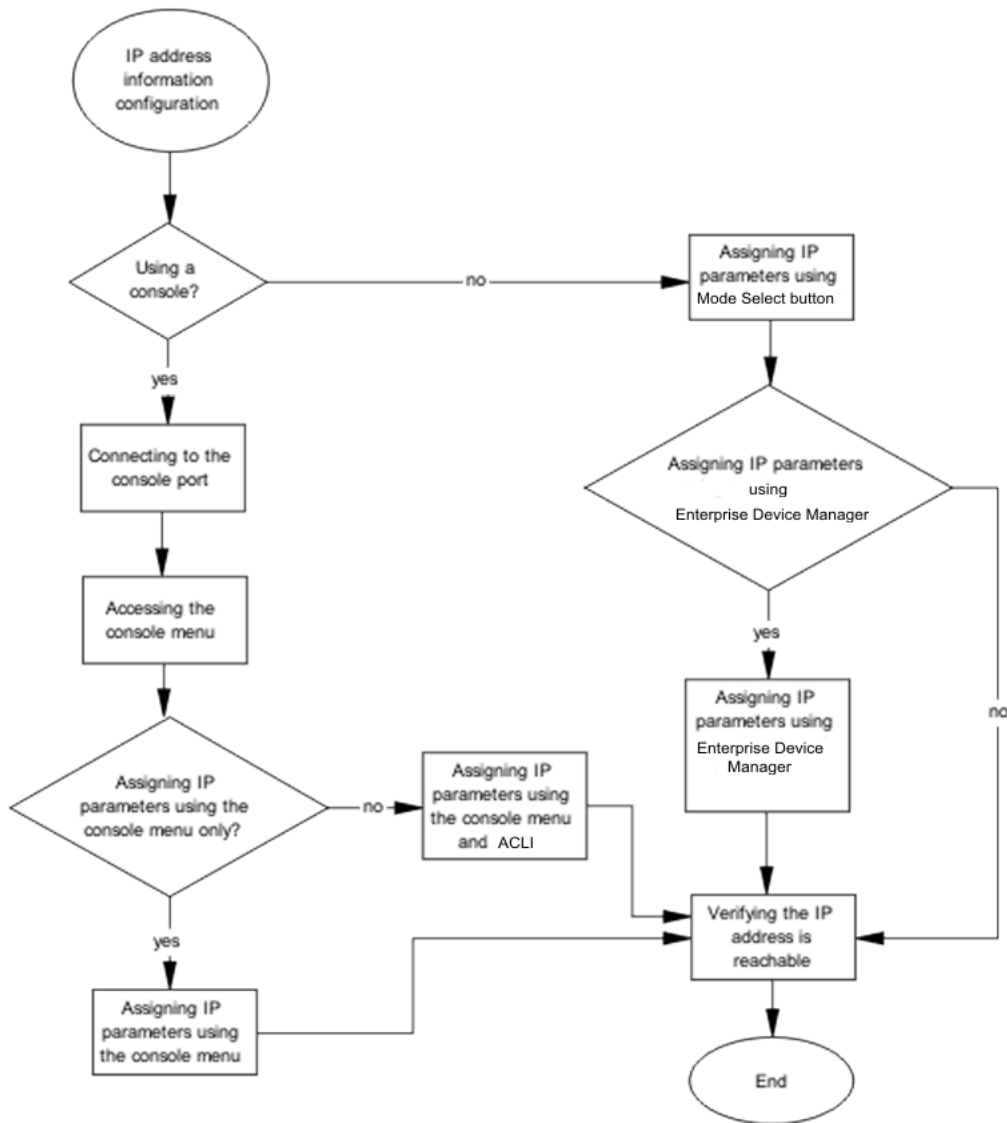

Navigation:

- [Accessing the console menu](#) on page 82
- [Assigning IP parameters using the console menu](#) on page 82
- [Assigning IP parameters using the UI/Mode Select button](#) on page 84
- [Assigning IP parameters using Enterprise Device Manager](#) on page 84
- [Verifying assigned IP address is reachable](#) on page 85

Stack configuration

This task flow shows the sequence of procedures you perform to configure a stack.

Stack Configuration Task Flow

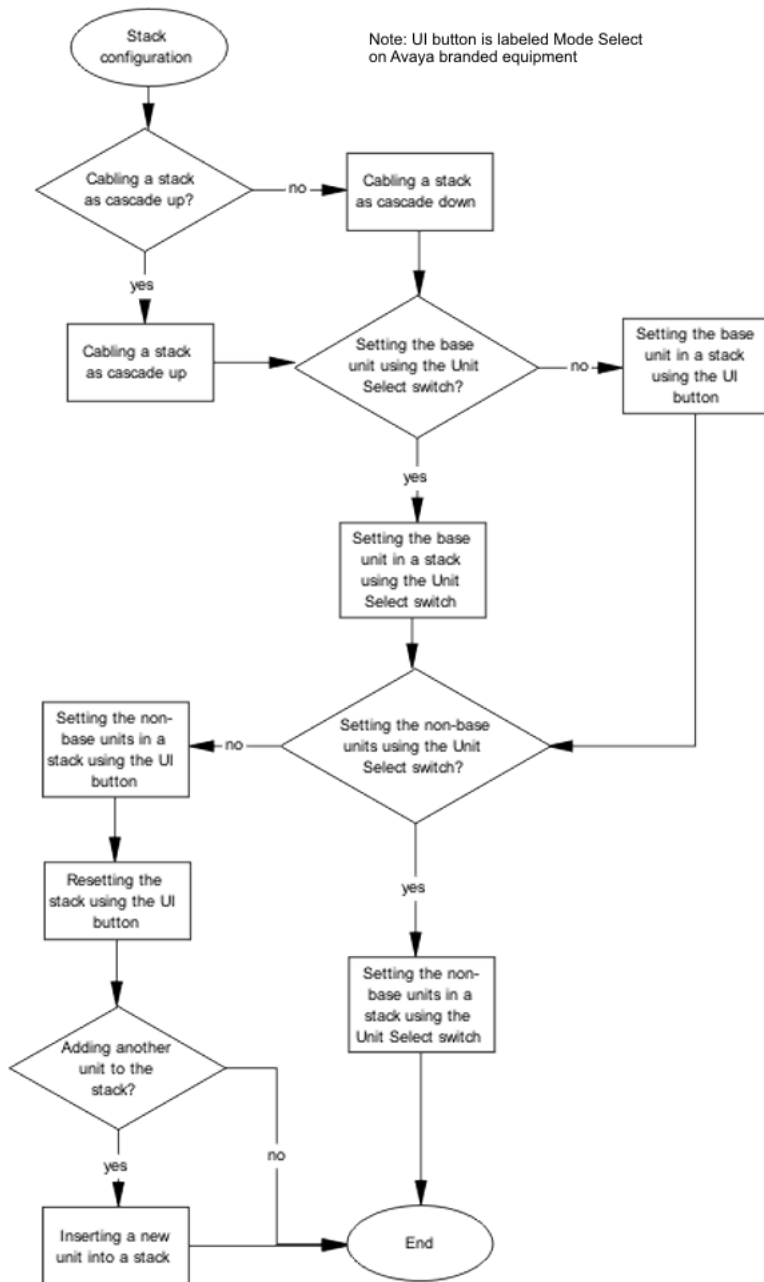

Navigation:

- [Cabling a stack](#) on page 86
- [Selecting a base unit](#) on page 89
- [Selecting a base unit using the UI/Mode Select button](#) on page 90

- [Setting non-base units](#) on page 90
- [Setting non-base units using the UI/Mode Select button](#) on page 90
- [Resetting a stack using the UI/Mode Select button](#) on page 91
- [Hybrid stack recommendations and limitation](#) on page 91

Chapter 6: Procedures for installation of the switch

Installation preparation

About this task

This procedure describes how to prepare to install a switch.

Warning:

To avoid bodily injury from hazardous electrical shock and current, never remove the top of the device. There are no user-serviceable components inside.

Procedure

1. Determine the type of installation
 2. Prepare the site.
 3. Collect the tools required to install a switch.
-

Verifying environment suitability

About this task

This procedure describes how to verify environment suitability.

Procedure

1. To verify environmental suitability for installation of the ERS 5500 Series switch, ensure that the area where you want to install and operate the switch meets the requirements listed in [Table 8: Job aid: Ethernet Routing Switch 5500 Series environmental requirements](#) on page 58.
2. To verify environmental suitability for installation of the ERS 5600 Series switch, ensure that the area where you want to install and operate the switch meets the

requirements listed in [Table 9: Job aid: Ethernet Routing Switch 5600 Series environmental requirements](#) on page 59.

Job Aid

The following tables show the environmental requirements for the Ethernet Routing Switch 5500 and 5600.

Table 8: Job aid: Ethernet Routing Switch 5500 Series environmental requirements

	Avaya Ethernet Routing Switch 5510	Avaya Ethernet Routing Switch 5520	Avaya Ethernet Routing Switch 5530
Ambient Temperature	Between 32 and 113 degrees Fahrenheit (0 and 45 degrees Celsius).	Between 32 and 104 degrees Fahrenheit (0 and 40 degrees Celsius) for continuous operation. This operational temperature can be extended to 131 degrees Fahrenheit (55 degrees Celsius) for short time operation.	Between 32 and 122 degrees Fahrenheit (0 and 50 degrees Celsius) for continuous operation. This operational temperature can be extended to 140 degrees Fahrenheit (-10 to 60 degrees Celsius) for short time operation.
Storage Temperature	Between -40 and 185 degrees Fahrenheit (-40 and 85 degrees Celsius).	Between -40 and 185 degrees Fahrenheit (-40 and 85 degrees Celsius).	Between -40 and 185 degrees Fahrenheit (-40 and 85 degrees Celsius).
Operating Relative Humidity	Between 5 and 85% non-condensing.	Between 10 and 90% non-condensing.	Between 10 and 90% non-condensing.
Storage Relative Humidity	Between 10 and 95% non-condensing.	Between 10 and 95% non-condensing.	Between 10 and 95% non-condensing.
Maximum Operating Altitude	10,000 feet (3048 meters) above sea level.	10,000 feet (3048 meters) above sea level.	15,000 feet (4572 meters) above sea level.
Storage Altitude	Between -1,000 and 10,000 feet	Between -1,000 and 10,000 feet	Between -1,000 and 40,000 feet (-340.8

	Avaya Ethernet Routing Switch 5510	Avaya Ethernet Routing Switch 5520	Avaya Ethernet Routing Switch 5530
	(-304.8 and 3048 meters) above sea level.	(-304.8 and 3048 meters) above sea level.	and 12,192 meters) above sea level.
Miscellaneous Operating Considerations	<ul style="list-style-type: none"> • No heat sources such as hot air vents or direct sunlight located near the switch. • No sources of severe electromagnetic interference located near the switch. • No excessive dust in the environment. • An adequate power source is located within 6 feet (1.83 meters) of the switch. One 15-amp circuit is required for each power supply. • At least 2 inches (5.08 centimeters) of clearance on each side of the switch unit for ventilation. • Adequate clearance is allotted at the front and rear of the switch for access to cables. 		

Table 9: Job aid: Ethernet Routing Switch 5600 Series environmental requirements

Storage temperature	-40° to 85°C
Operating temperature	: 0° to 50°C (continuous operational.) 0° to 55°C (short term operational)
ESS temperature	-5° to 55°C
Operating relative humidity	10 to 90% non-condensing
Storage relative humidity	10 to 95% non-condensing
Operating altitude	13,000 feet above sea level
Storage altitude	-1,000 to 40,000 feet above sea level
Cooling	Dependent on system requirements
Audible noise	45dB to 55dB nominal
DMT temperature	-10° to 60°C
DVT temperature	-15° to 65°C
Miscellaneous Operating Considerations	<ul style="list-style-type: none"> • No heat sources such as hot air vents or direct sunlight located near the switch. • No sources of severe electromagnetic interference located near the switch. • No excessive dust in the environment.

	<ul style="list-style-type: none">• An adequate power source is located within 6 feet (1.83 meters) of the switch. One 15-amp circuit is required for each power supply.• At least 2 inches (5.08 centimeters) of clearance on each side of the switch unit for ventilation.• Adequate clearance is allotted at the front and rear of the switch for access to cables.
--	--------------------------------------------------------------------------------------------------------------------------------------------------------------------------------------------------------------------------------------------------------------------------------------------------------------------------------------------------------------------------------------------------------

Verifying the contents of the box

About this task

This section describes how to verify the package contents for Ethernet Routing Switch 5000 Series products.

Verifying package contents for Ethernet Routing Switch 5500:

To verify that all components have been delivered for each Ethernet Routing Switch 5500, compare the package contents with those shown and listed in the following figure. If any components are missing, contact the vendor from whom you purchased the switch.

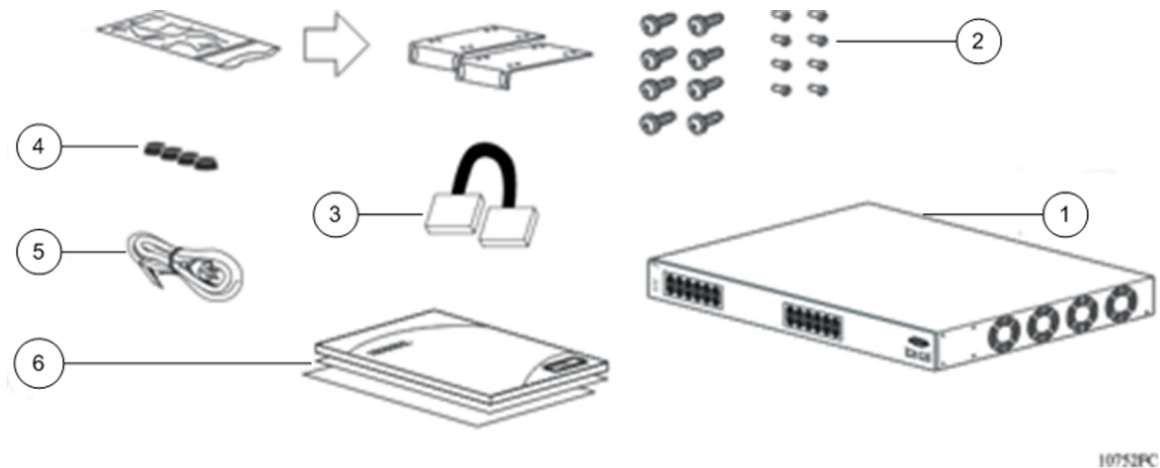

Figure 7: Ethernet Routing Switch 5500 Series package contents

1. Avaya Ethernet Routing Switch 5500 Series
2. Rack-mounting hardware that includes:
 - Rack-mount brackets.

*** Note:**

The Avaya Ethernet Routing Switch 5530-24TFD offers 24 inch rack mounting brackets.

- Screws for attaching brackets to the switch
- Screws for attaching the switch to the equipment rack

3. Stacking cable
4. Rubber footpads
5. AC power cord
6. Documentation

Verifying package contents for Ethernet Routing Switch 5600:

To verify that all components have been delivered for each Ethernet Routing Switch 5600, compare the package contents with those shown and listed in the following figure. If any components are missing, contact the vendor from whom you purchased the switch.

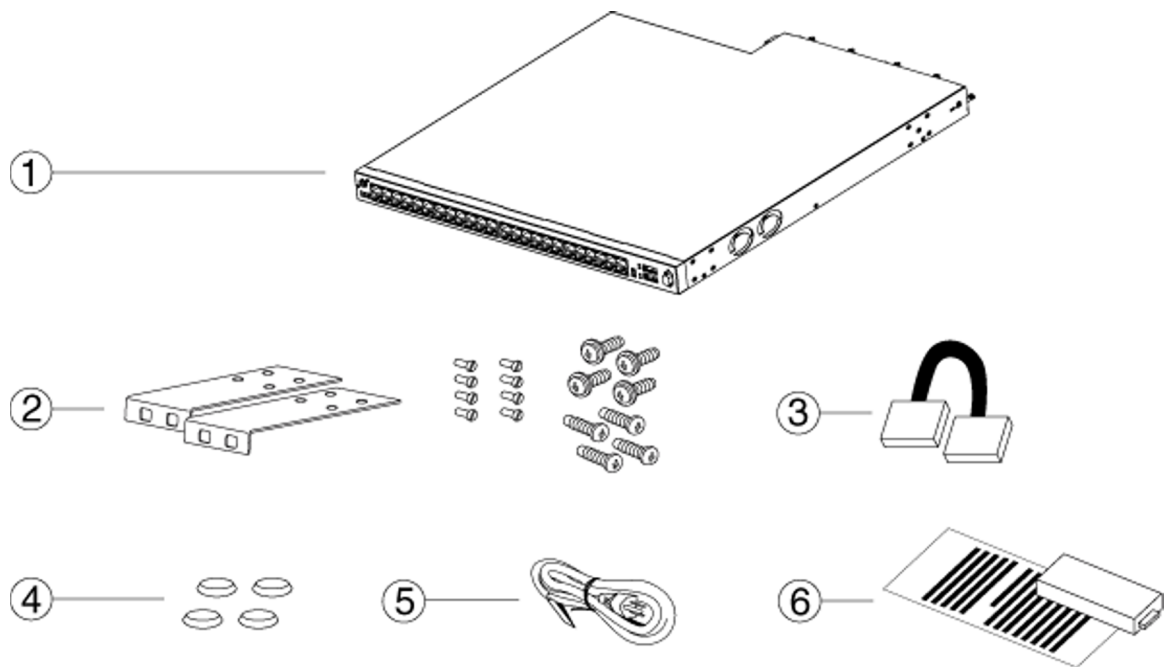

Figure 8: Ethernet Routing Switch 5600 Series package contents

1. Avaya Ethernet Routing Switch 5600 Series
2. Rack-mounting hardware that includes:
 - Rack-mount brackets (two for a 19-inch equipment rack and two for a 23-inch equipment rack)
 - Screws for attaching brackets to the switch
 - Screws for attaching the brackets to the equipment rack
3. Stacking cable

4. Rubber footpads
5. Country-specific AC power cord or DC adapter
6. Power supply module and related documentation

Switch placement

About this task

The following sections describes the various methods of mounting or placing a switch.

Mounting on a table or shelf

About this task

This procedure describes how to mount 5000 Series switches on a table or a shelf.

A single 5000 Series Switch can be installed on any flat surface. The surface should be able to support the combined weight of the switch and attached cables; between 15 and 20 lbs (7 to 9 kg) for a 5500 Series switch, and between 21 and 33 lbs (9.5 to 15 kg) for a 5600 Series switch..

Caution:

Do not place an Avaya Ethernet Power Supply Unit 10 or an Avaya Ethernet Redundant Power Supply 15 on top of an Avaya Ethernet Routing Switch 5500 Series. The switch housing of a 5500 Series Avaya Ethernet Routing Switch is not strong enough to support the weight of these units.

Procedure

1. Using [Figure 9: Attaching rubber footpads to a 5500 Series switch](#) on page 63 as a guide, attach the provided rubber footpads to the bottom of the switch in the locations shown.

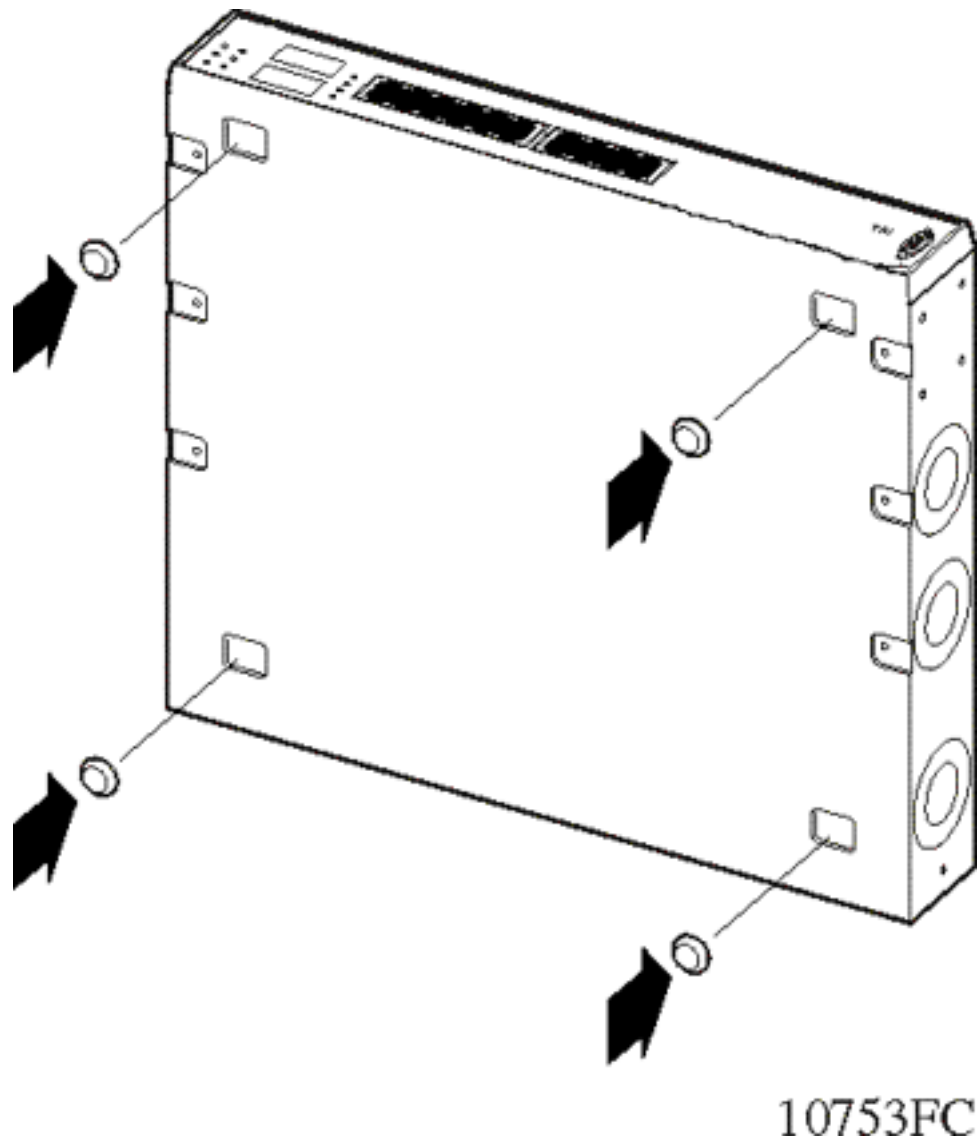

Figure 9: Attaching rubber footpads to a 5500 Series switch

2. Set the switch on a table or shelf as shown in [Figure 10: Ethernet Routing Switch 5000 Series on a table or shelf](#) on page 64. Allow at least 2 inches (5.1 centimeters) on each side for proper ventilation and at least 5 inches (12.7 centimeters) at the back for power cord clearance.

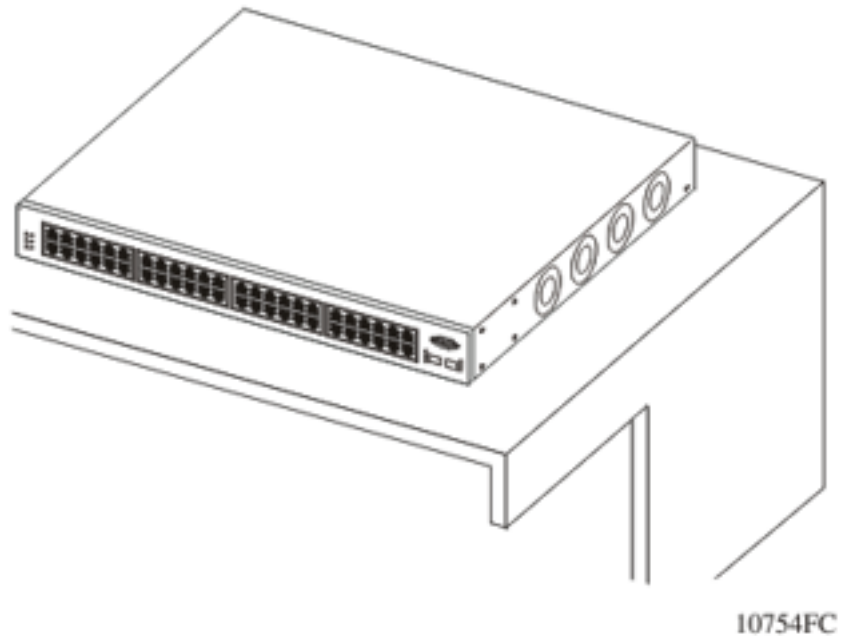

Figure 10: Ethernet Routing Switch 5000 Series on a table or shelf

Mounting on a wall

This procedure describes how to mount a 5000 Series switch on the wall.

Before you begin

- Phillips #2 screwdriver
- Wall anchors and screws

About this task

One 5500 Series switch weighs as much as 11.6 lbs (5.26 kg), and one 1U 5600 Series switch weighs as much as 30 lbs (13.6 kg). Ensure you choose fasteners appropriate for the weight of the unit. One person can lift and install the 5500 Series switch. Avaya recommends that two people lift and install a 5600 Series switch.

Procedure

1. Attach the brackets to each side of the device as shown in [Figure 11: Wall mount bracket detail](#) on page 65.
2. Secure the brackets to the wall using appropriate screws and wall anchors (not provided) [Figure 12: Wall mount mounting screw location](#) on page 66.

Job Aid

The following figures show the wall mount bracket detail.

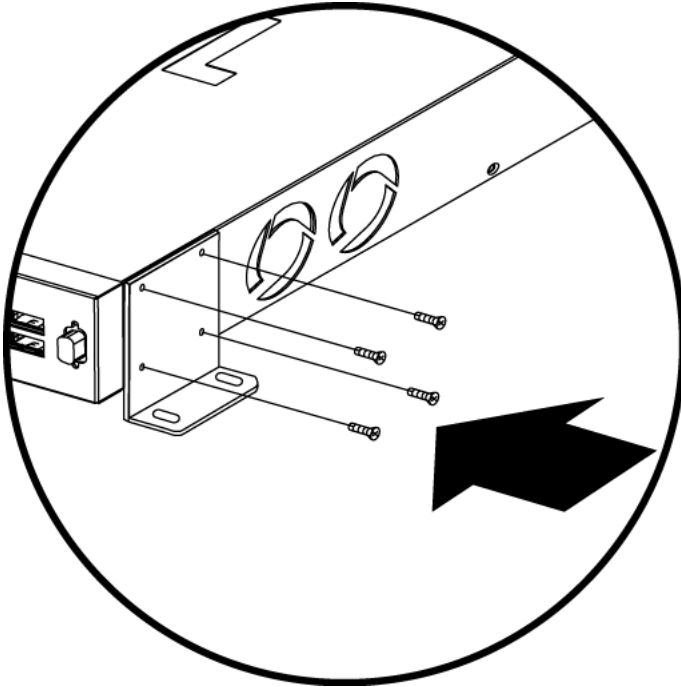

Figure 11: Wall mount bracket detail

The following figures show the wall mount screw location.

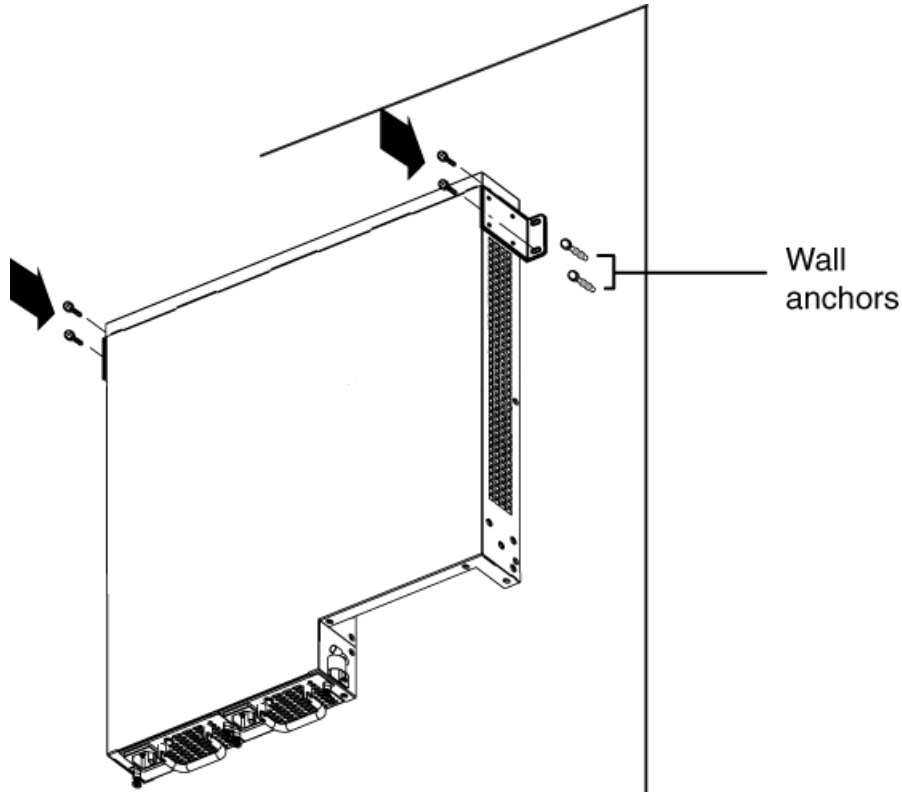

Figure 12: Wall mount mounting screw location

Installing a front mounted switch in an equipment rack

This procedure describes how to install a front mounted switch in a rack.

Before you begin

- #2 Phillips screwdriver

Procedure

1. Attach a bracket to each side of the switch using a #2 Phillips screwdriver as illustrated in [Figure 13: Bracket installation](#) on page 67. The bracket with the round holes goes on the right side of the switch, where the round fan vents are located.
2. Slide the switch into the rack as illustrated in [Figure 14: Rack mount](#) on page 68. Insert and tighten the rack-mount screws with a #2 Phillips screwdriver.

Job Aid

The following figures show the bracket installation.

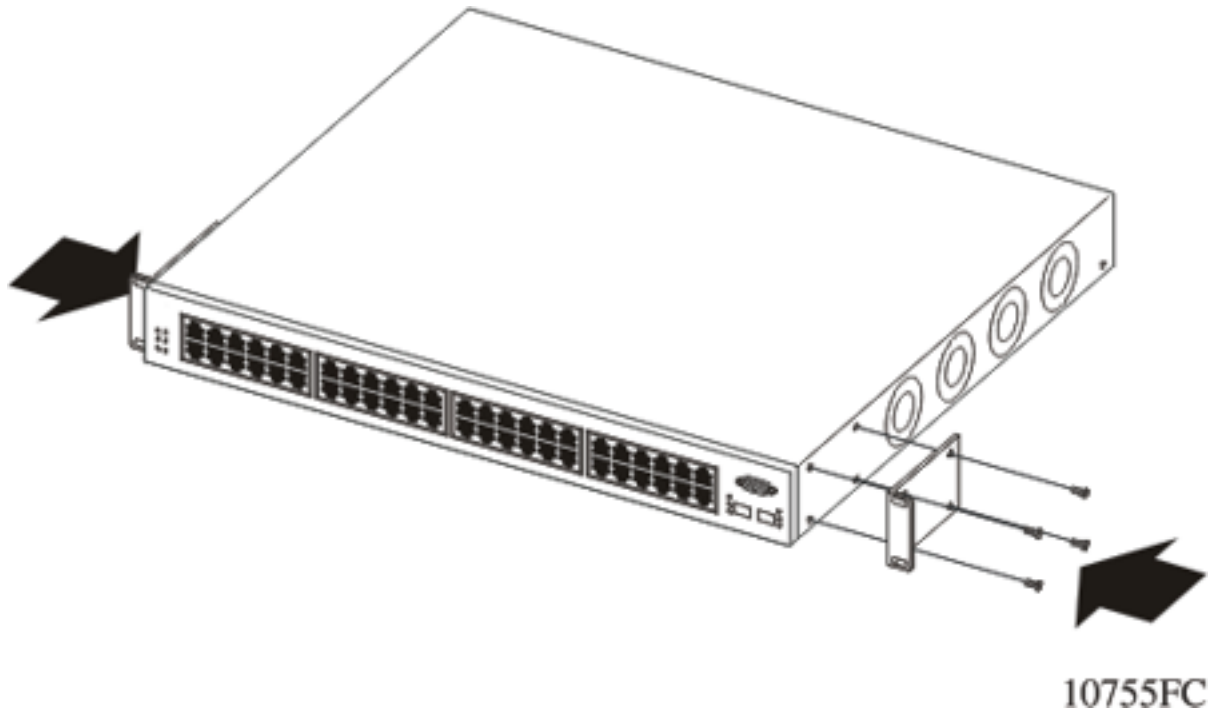
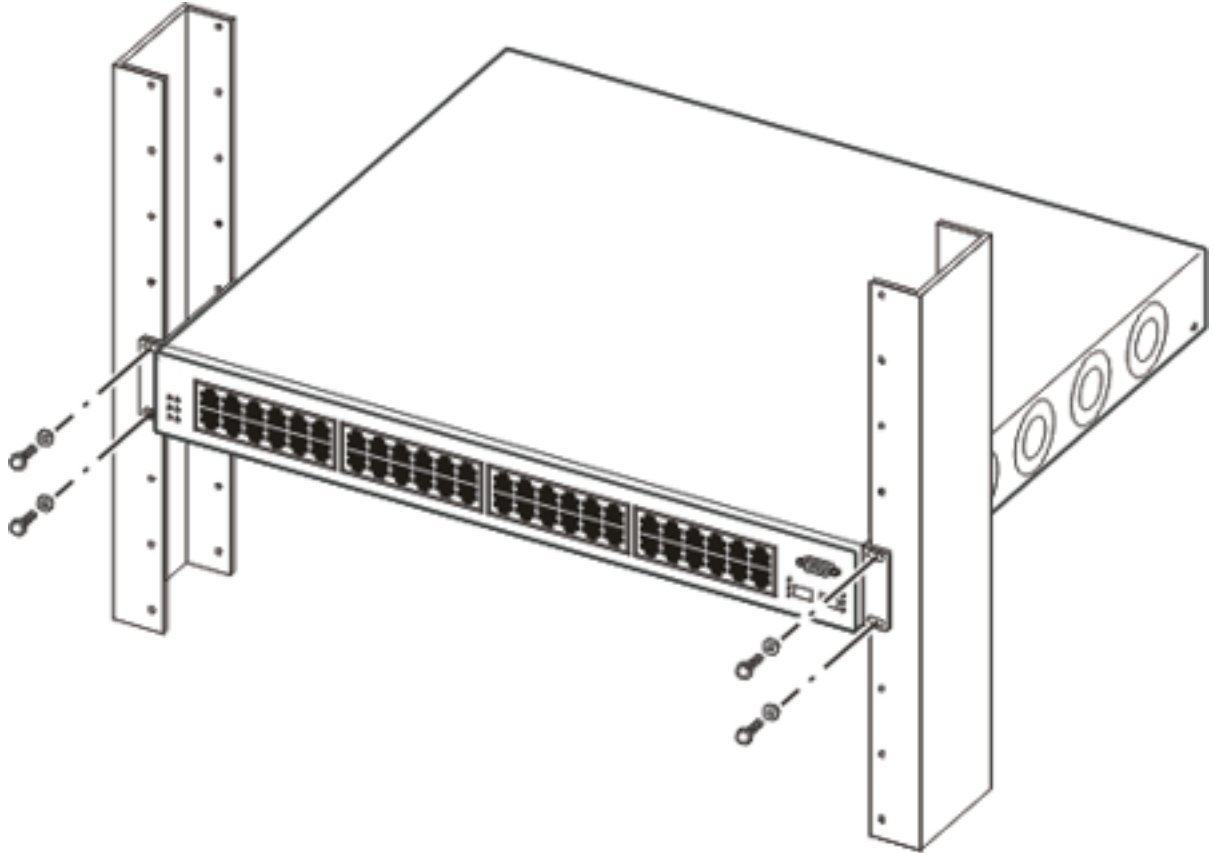

Figure 13: Bracket installation

The following figures show the rack mount.



10756FC

Figure 14: Rack mount

Installing a rear mounted switch in an equipment rack

About this task

The Ethernet Routing Switch 5530-24TFD and 5600 Series switches offer the option of installing the switch in a rear mounted configuration. This option allows the switch to be installed with the back panel facing forward. This procedure describes how to install a rear-mounted switch.

Prerequisites

- #2 Phillips screwdriver

Procedure

1. Attach a bracket to each side of the switch using a #2 Phillips screwdriver as shown in [Figure 15: Attaching rear mounted switch brackets](#) on page 69. The bracket

with the round holes goes on the right side of the switch where the round fan vents are located.

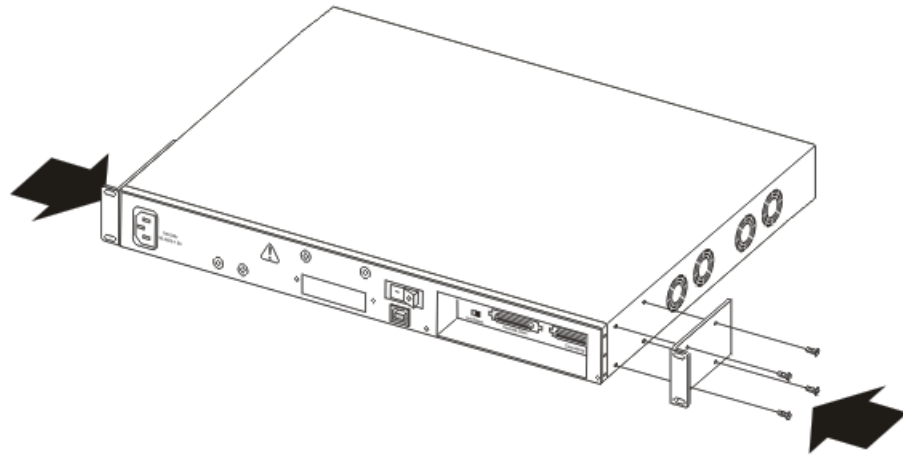

Figure 15: Attaching rear mounted switch brackets

2. Slide the switch into the rack as shown in [Figure 16: Rear mounted switch configuration](#) on page 70. Insert and tighten the rack-mount screws with a #2 Phillips screwdriver.

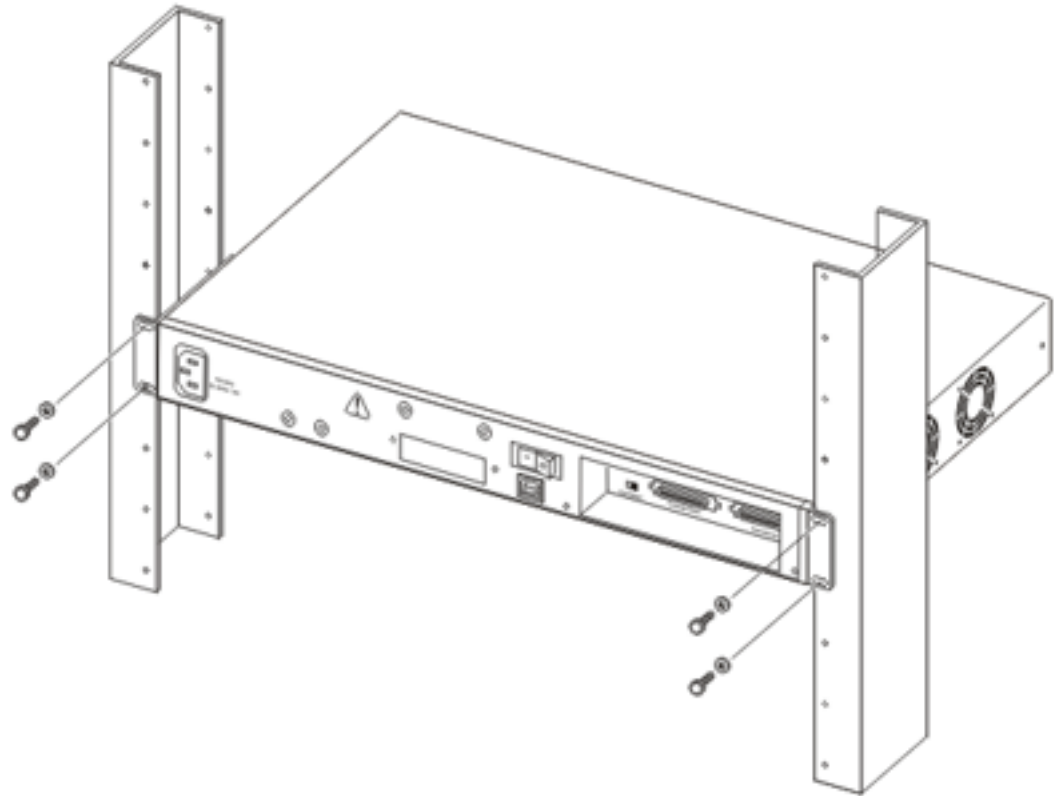

Figure 16: Rear mounted switch configuration

Power connection

About this task

These procedures describe the steps to connect power sources to the switches.

Installing a power supply module in a 5600 Series switch

This procedure describes the step necessary to install a power supply module in a 5600 Series switch.

Before you begin

- #2 Phillips screwdriver

About this task

Electrostatic alert:

To prevent damage from electrostatic discharge, always wear an antistatic wrist strap connected to an ESD jack when performing maintenance on a 5000 Series switch. Ensure that the wrist strap makes contact with your skin.

Procedure

1. Use a Phillips screwdriver to loosen the two screws that secure the metal plate that covers the slot in which you want to install the power supply module.
2. Remove the cover plate.
3. Insert the power supply module in the power supply slot. The following figure shows the power supply module inserted in a 5600 Series switch.

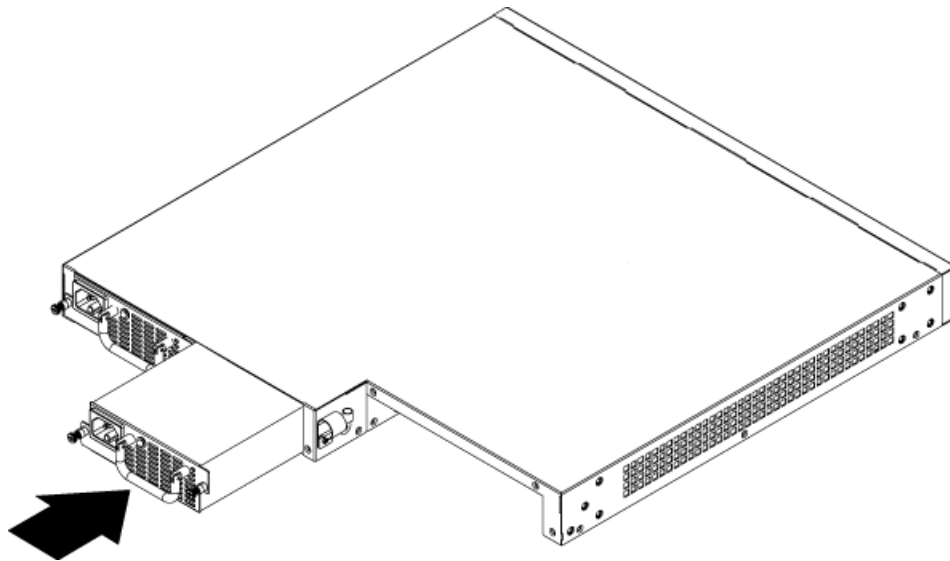

4. Push the power supply module gently, but firmly, to insert it fully into the internal connection port. When the power supply is fully inserted, the front of the power supply unit is flush with the rear panel of the switch.
5. Secure the power supply module in the chassis by tightening the two retaining screws. The following figure shows the captive screws.

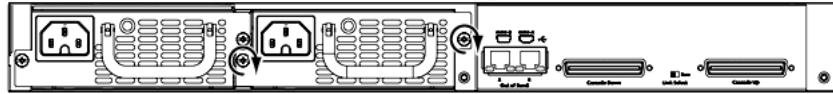

Connecting an AC cord to switch

This procedure describes the steps used to connect an AC power cord to the switch.

Before you begin

To connect AC power to the switch an appropriate AC power cord is required.

About this task

Danger:

Use only power cords that have a grounding path. Without a proper ground, a person who touches the switch is in danger of receiving an electrical shock. Lack of a grounding path to the switch may result in excessive emissions.

Procedure

1. Connect the AC power cord to the back of the switch and then connect the cord to an AC power outlet. The following figure illustrates connecting the AC power cord to the switch back panel.

Important:

The 5000 Series switches do not have an AC power switch. When the power cord is connected to a suitable AC power outlet, the switch powers up immediately.

Warning:

Disconnecting the AC power cord is the only way to turn off AC power to the 5000 Series switches. Always connect the AC power cord in a location that can be reached quickly and safely in case of an emergency. For a translation of this statement, see [Translations of safety messages](#) on page 13.

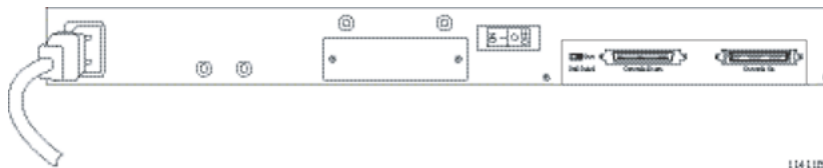

2. Insert the male end of the power cord in a standard 110/220 V AC power outlet.

Caution:

Ensure you use an appropriately rated AC power cord only. Do not use an extension cord.

Installing a redundant power supply in a 5500 Series switch

This procedure describes the steps to install a redundant power supply. This procedure applies only to 5500 Series switches.

Before you begin

Before you install and use the redundant power supply, ensure the area housing the RPS 15 chassis meets the following environmental requirements:

- Ambient temperature between 0° and 40° C (32° and 104° F)
- Relative humidity between 5% and 85% noncondensing
- No nearby heat sources such as hot air vents or direct sunlight
- No nearby sources of severe electromagnetic noise
- No excessive dust
- Adequate power source within 6 feet (1.83 m); one 15-Amp circuit required for each power supply
- At least 2 inches (5.08 cm) on each side of the chassis for ventilation
- Adequate space at the front and rear of the chassis for access to cables

Procedure

1. If you are installing the first RPS 15 module into the empty center chassis slot, proceed to step 2. Otherwise, remove one of the blank panels on the front of the chassis.
 2. Insert an RPS 15 power supply module into the empty slot.
 3. Verify that the module is firmly seated in the slot.
 4. Use the thumbscrews to fasten the faceplate to the chassis and secure the power supply module.
 5. Repeat these steps for each power supply module that you must install.
-

Installing DC-DC converter in a 5500 Series switch

This procedure describes the steps used to install a DC-DC converter. This procedure applies only to 5500 Series switches.

Before you begin

Electrostatic discharge can damage the components on circuit boards. When you unpack the converter module, take the following precautions to prevent damage to the board:

- Do not remove the converter module from its antistatic plastic bag until you are ready to install it. Store or ship the converter module and components in antistatic packaging.
- Check the converter module for damage. If you find damage, contact your sales or customer service representative at the organization from which you purchased the equipment.
- Use proper grounding techniques when you install the converter module. You can use a foot strap and grounded mat or wear a grounded static discharge wrist strap.

Warning:

Removal of the power cord is the only way to turn off power to 5000 Series switches. The power cord must always be connected in a location that can be accessed quickly and safely in case of an emergency.

Procedure

1. Make certain you are properly grounded electrically. See [Prerequisites](#) on page 74.
 2. The 5000 Series switch has a blank plate covering the converter module slot on the back of the switch. Use a Phillips screwdriver to remove the screws. Pull the plate gently toward you to pull the plate loose.
 3. Set aside the blank plate and the screws. If you remove the converter module for any reason, be sure to reinsert the blank plate.
 4. Holding the converter module by the sides, slide the converter module into the 5000 Series switch using the guide rails. Press firmly to make sure that the converter module is fully seated.
 5. Fasten the converter module screws to the switch using a screwdriver.
-

Connecting a DC power source to a 5600 Series switch

This procedure describes the steps necessary to connect a DC power source to a 5600 Series switch.

Before you begin

- Ensure the DC power source is switched off.

Procedure

1. Plug the DC adapter into the power supply module.
 2. Connect the DC leads to the adapter terminal block.
 3. Tighten the screws on top of the adapter terminal block to secure the DC leads.
 4. Attach the opposite ends of the leads to a –48V DC power source.
-

Hardware installation verification

Checking LEDs

About this task

This procedure describes how to check and interpret LEDs on the 5000 Series switches.

Procedure

To check and interpret front panel LEDs, compare the LEDs to the tables in the Job Aids section.

Job Aid

The following tables describe the LED indicators.

Table 10: Job aid: Switch LED state indicators

Label	Color / Status	Description
UI button	White/steady	Power is on.

Label	Color / Status	Description
	Off	Power is off.
<p>* Note: The UI button is labeled Mode Select on Avaya branded equipment.</p>		
Pwr	Green / steady	The switch is connected to AC power and is receiving power.
	Green / blinking	Problem with primary Boot image. Booted from back up image. Configuration and agent code may be incorrect.
	Amber / slow blinking	System will reset in less than 3 seconds. To stop the reset, release UI push button. * Note: The UI button is labeled Mode Select on Avaya branded equipment.
	Amber / fast blinking	System will reset in less than 1 second. To stop the reset, release UI push button. * Note: The UI button is labeled Mode Select on Avaya branded equipment.
	Off	The switch is not connected to an AC power source or the power supply unit is not supplying power.
Status	Green / steady	<ul style="list-style-type: none"> • During Initialization: The power-on self-test is complete and the switch is operating normally. • After Initialization: The front panel configuration mode is inactive. Unit booted successfully.
	Green / blinking	<ul style="list-style-type: none"> • During Initialization:: A non-fatal error occurred during the self-test. • After Initialization: The user pushed the UI button and activated the front panel configuration mode and the system is awaiting input.
	Amber / steady	<ul style="list-style-type: none"> • During Initialization: N/A • After Initialization: The front panel has accepted the user command. The system accepts the UI input and is awaiting execution.
	Amber / blinking	<ul style="list-style-type: none"> • During Initialization: N/A • After Initialization: The system has rejected the UI input.
	Off	The switch failed the self-test.

Label	Color / Status	Description
RPSU	Green / steady	The switch is connected to a redundant power supply unit (RPSU) and is receiving power if necessary.
	Off	The switch is not connected to a RPSU, the RPSU is not supplying power, or the DC/DC module is not supplying power.
Up	Green / steady	The Cascade Up port has a physical connection to another unit.
	Amber / steady	The Cascade Up port has detected an error.
	Off	The switch is in standalone mode or there is no link to the Cascade Up port.
Down	Green / steady	The Cascade Down port has a physical connection to another unit.
	Amber / steady	The Cascade Down port has detected an error.
	Off	The switch is in standalone mode or there is no link to the Cascade Down port.
Base	Green / steady	The switch is the stack base unit.
	Green / blinking	There is a stack configuration error. Either multiple base units or no base units are configured in the stack.
	Amber / steady	The switch is operating as the temporary base unit in the stack configuration.
	Off	The switch is not the stack base unit or it is operating in standalone mode.

Table 11: Port LED state indicators for 5510 and 5530 Switches

Label	Color / Status	Description
Speed	Green / steady	The port is set to operate at 1000 Mbps.
	Amber / steady	This port is set to operate at 100 Mbps
	Off	When the LNK/ACT LED is green, this port is set to operate at 10 Mbps. When this LED is off, refer to the LNK/ACT section for more information.
LNK/ACT	Green / steady	The link is operating normally.
	Green / blinking	There is activity on the port. The blinking rate indicates the level of activity.
	Green / slow blinking	The port has been disabled by the software.
	Off	The port has no link nor activity.

Table 12: Port LED state indicators for 5520 Switches

Label	Color / Status	Description
Speed	Amber / steady	100 Mbps - PoE is off
	Amber / pulsing	100 Mbps - PoE is on
	Green / Amber Alternating	10 Mbps or No link or Admin disabled or PoE is on. Refer to the speed setting configured for this port to determine the specific state.
	Green / steady	1000 Mbps - PoE is off
	Green / pulsing	1000 Mbps - PoE is on
	Off	10 Mbps or No link or Admin disabled or PoE is off. Refer to the speed setting configured for this port to determine the specific state.
LNK/ACT	Amber / steady	PoE DTE short or the power allocated to this port has been exceeded.
	Amber / blinking	Power budget exceeded.
	Green / steady	Link established but no data activity.
	Green / blinking	There is activity on this port. The blinking rate indicates the level of activity.
	Off	No link.

Table 13: Shared SFP transceiver Port LED state indicators

Label	Color / Status	Description
In Use	Green / steady	The port has a link established.
	Off	The port does not have a link established.
LNK/ACT	Green / steady	This link is operating normally.
	Green / blinking	There is activity on the port.
	Green / slow blinking	The port has been disabled by the software.
	Off	Indicates that the link has been lost.

Table 14: XFP transceiver port LED state indicators

LED Color / Status	Description
Tx Green / steady Rx Green / steady	Link established.
Tx Green / blinking	Transmit activity detected.
Rx Green / blinking	Receive activity detected.

LED Color / Status	Description
Tx Amber / steady	Transmit activity enabled.
Rx Amber / steady	Fiber connected with signal present.
Tx Amber / blinking	XFP has been installed. Laser Transmitter OFF or XFP in Reset.
Rx Amber / blinking	XFP has been installed. No Signal Detected or XFP in Reset.
Both Off	No XFP installed.
The Amber LEDs are usually only used during the boot process. Under normal operation, Green is the only color the XFP LED should emit.	

Preparations for network connectivity

About this task

The following section contains procedures used to prepare 5000 Series switches for network connectivity.

Cabling a standalone switch

This procedure describes the steps used to cable a standalone switch.

Before you begin

- The following table lists the required cables for an Avaya Ethernet Routing Switch 5500 Series and their specifications.

Important:

In Autonegotiation mode, the Ethernet Routing Switch 5500 Series automatically provides the proper MDI/MDI-X connection on the RJ-45 ports; thereby eliminating the need for crossover cables. When Autonegotiation is disabled on 10/100 ports, they are configured as an MDI-X connection.

Procedure

1. Mount the switch. You can mount a standalone switch on a table or shelf, the wall, or in a rack.
2. Connect the ground cable to the switch.
3. Attach the required cables to the switch.
4. Install any required transceivers.

5. Connect the AC power cord.

Job Aid

The following figure show the location of the grounding lug on a 5600 Series switch.

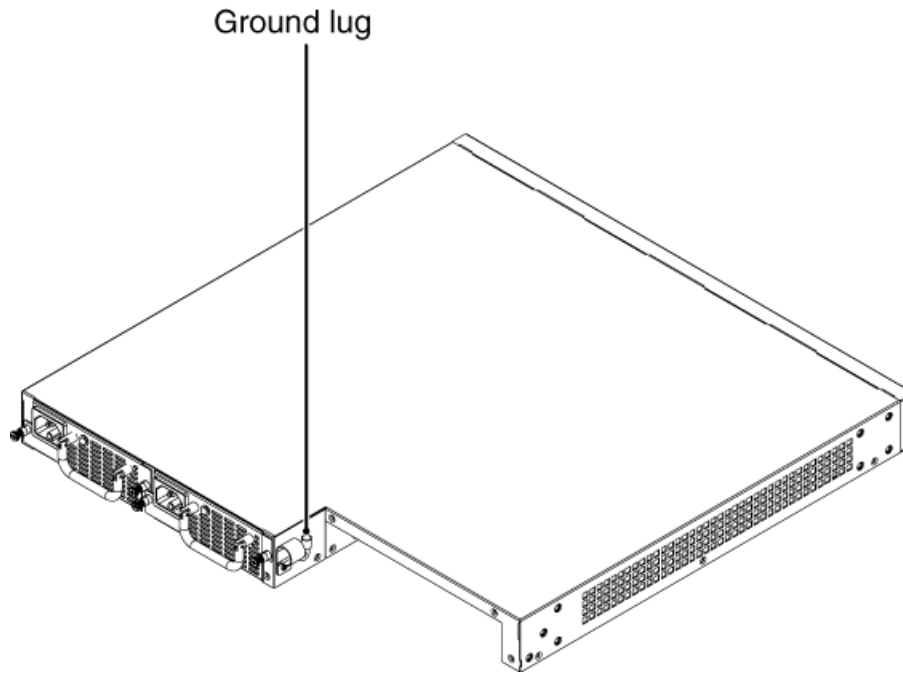

Figure 17: Job aid: Grounding lug location on a 5600 Series switch

Installing transceivers

About this task

This procedure describes the steps used to install transceivers.

Procedure

1. Remove the transceiver from the protective packaging.
2. Verify that the transceiver is the correct model for the network configuration.
3. Grasp the transceiver between the thumb and forefinger.
4. Insert the transceiver into the proper module on the switch. Apply a light pressure to the transceiver until it clicks and locks into position in the module.

5. Remove the dust cover from the transceiver optical bores.

Job Aid

The following graphic shows and SFP transceiver.

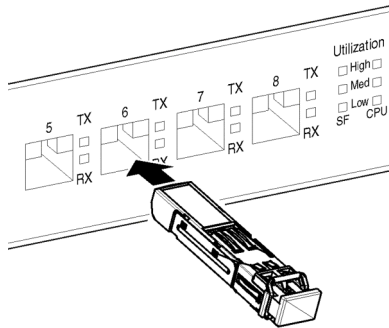

Figure 18: SFP transceiver

IP address information configuration

About this task

The following sections contain information necessary to configure IP address parameters on the switch.

Connecting a console

This procedure describes the steps to connect a console.

Before you begin

- Terminal with AC power cord and keyboard.
- Serial cable with a DB-9 female connector on both ends. The maximum length for the console port cable is 25 feet (8.3 meters).

Procedure

1. Connect one end of serial cable to the DB-9 connector on the terminal.
 2. Connect the other end of the serial cable to the DB-9 connector on the switch.
 3. Turn the terminal on.
-

Accessing the console menu

About this task

This procedure describes the steps used to access the console menu.

Procedure

1. Connect a terminal to the console port of the switch.
 2. Set the terminal protocol on the terminal or terminal emulation program to VT100 and VT100/ANSI.
 3. Connect to the switch using the terminal or terminal emulation application.
 4. After the Avaya banner is displayed, press CTRL + Y to display the main menu. The version of the main menu displayed is dependent on whether the switch is part of a standalone or stacked switch configuration.
-

Assigning IP parameters using the console menu

About this task

This procedure describes the steps used to assign IP parameters using the console menu.

Procedure

1. From the console menu, select IP Configuration/Setup.
 2. Assign an IP address to the switch.
 - For a standalone switch, enter a value in the In-Band Switch IP Address field in dotted-decimal notation.
 - For a stack configuration, enter a value in the In-Band Stack IP Address field in dotted-decimal notation.
 3. In the In-Band Subnet Mask field enter the appropriate subnet mask in dotted-decimal notation.
 4. In the Default Gateway field, enter the appropriate default gateway in dotted-decimal notation.
 5. Press CTRL + C to return to the main menu.
-

Assigning IP parameters using the console menu and ACLI

Procedure

1. Connect a terminal to the console port of the switch.
 2. Set the terminal protocol on the terminal or terminal emulation program to VT100 and VT100/ANSI.
 3. Connect to the switch using the terminal or terminal emulation application.
 4. After the Avaya banner is displayed, press CTRL + Y to display the main menu.
 5. Select **Command Line Interface . . .** from the main menu.
 6. Enter the Global Configuration command mode using the **enable** and **configure terminal** commands.
 7. In the Global Configuration command mode, use the **ip address** command to set the switch or stack IP address.
 8. Initial IP configuration is now complete. To continue with configuration operations, use the appropriate CLI commands. To disconnect from the switch use the **logout** command to return to the Console Menu and select **Logout** from the main menu.
-

Job aid

Any terminal or PC with an appropriate terminal emulator can be used as the management station. The following table lists the parameters that must be used with any terminal emulation software used to connect to the switch.

Table 15: Terminal emulation settings

Property	Value
Baud Rate	9600 bps
Data Bits	8
Stop Bits	1
Parity	None
Flow Control	None

Assigning IP parameters using the UI/Mode Select button

About this task

This procedure describes the steps to assign IP parameters using the UI button.

*** Note:**

The UI button is labeled **Mode Select** on Avaya branded equipment.

Procedure

1. Press and hold the UI button for 3 seconds.
The unit enters configuration mode. The Status LED changes to a blinking green status.
2. Press the UI button 5 times.
The Base LED and the Up and Down LEDs are now steady amber to indicate that the button press was recognized.
3. Press the UI button and hold it in for 3 seconds to confirm the command.
The In-Use IP address changes to the IP address of your switch.
The color and status of the Status LED turns to steady green when the system accepts the command. If the system rejects the command, the Status LED turns to amber blinking.
Initial IP configuration using the UI/Mode Select button is complete.
To continue switch configuration, access the switch through the ACLI or Enterprise Device Manager.

Assigning IP parameters using Enterprise Device Manager

About this task

The following procedure describes how to use Quick Start to assign IP parameters to the ERS 5000 Series switch.

Procedure

1. Connect a computer to the switch through a data port using a standard RJ-45 network cable.
2. Open a web browser on the attached computer.
3. Enter the factory default IP address of the switch in the following format: `http://<IPAddress>`.
The main screen of the Enterprise Device Manager Interface opens.

4. From the navigation tree, click **Administration > Quick Start**.
The IP/Community/Vlan work area opens.
5. In the In-Band Stack IP Address dialog box, type a switch or stack IP address .
6. In the In-Band Subnet Mask dialog box, type a subnet mask.
7. In the Default Gateway dialog box, type an IP address.
8. Click **Apply**.

*** Note:**

For further switch configuration information, see *Avaya Ethernet Routing Switch 5000 Series Configuration-System* (NN47200–500).

Verifying assigned IP address is reachable

This procedure describes a method of verifying that the assigned IP address is reachable.

Before you begin

- Ensure you have assigned an IP address to the switch.
- Physically connect the switch to the network.
- Ensure the terminal from which you ping the switch is on the same network as the switch.

Procedure

Ping the 5000 Series switch from a terminal or workstation that is on the same network. If the network device sends a ping reply, a message indicates that the specified IP address is alive and can communicate with other devices.

Stack configuration

About this task

These procedures describe the steps to configure a stack.

If you want to integrate one or more 5600 Series switches into an existing 5500 stack, you have to install only one 5600 as Non-Base Unit (NBU) first. It can get the configuration from the Base Unit (BU) and integrate into the stack. Then you have to set the existing 5500 BU as NBU (using the switch) and the new 5600 to BU. Once the 5600 is the BU in the stack, you can add more 5600 Series switches to the stack without losing the existing 5500 configuration.

! Important:

You can change base unit switches with switches on (hot), but changes don't take effect until switches are rebooted.

Cabling a stack

This procedure describes the steps to cable a stack.

Before you begin

- The following table lists the required cables for an Avaya Ethernet Routing Switch 5500 Series and their specifications.

About this task

Table 16: Switch cabling requirements

Required Cable	Description
10/100/1GBase-T Ports	The interconnect cabling must conform to the Cat5e, Cat6, or Cat6e specification of the Commercial Building Telecommunications Cabling Standard, ANSI/TIA/EIA 568-B fitted with an RJ-45 Module Jack.
Console Port	Serial cable with a DB-9 female connector on both ends. The maximum length for the console port cable is 25 feet (8.3 meters).
Shared SFP Transceiver Ports	Varies with the installed SFP Transceiver. Refer to the documentation that was shipped with the SFP Transceiver for specifications.
XFP Transceiver Ports	Varies with the installed XFP Transceiver. Refer to the documentation shipped with the XFP Transceiver for specifications.
USB Ports	USB 2.0 compliant cable with a USB Type A connector on both ends.

! Important:

In Autonegotiation mode, the Avaya Ethernet Routing Switch 5500 Series automatically provides the proper MDI/MDI-X connection on the RJ-45 ports; thereby eliminating the need for crossover cables. When Autonegotiation is disabled on 10/100 ports, they are configured as an MDI-X connection.

Procedure

1. Choose a Cascade up or Cascade down arrangement.
2. Connect cables as shown in the Job Aid for each type.

3. Select the base unit.
4. Connect the console cable.
5. Connect the AC power cord.

If you assign the base unit and non-base units with the switches powered up, you must reset the switches for the assignments to be applied.

Stack configurations

The following illustrations show Cascade up and Cascade down cable arrangements, as well as the stack connectors for the 5500 and 5600 Series switches.

Procedures for installation of the switch

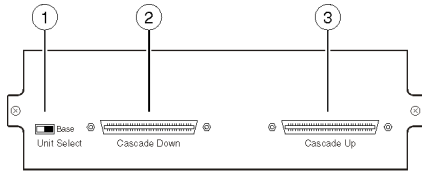

- 1 = Unit select switch
- 2 = Cascade down connector
- 3 = Cascade up connector

Figure 19: Job aid: 5500 Series stack connector

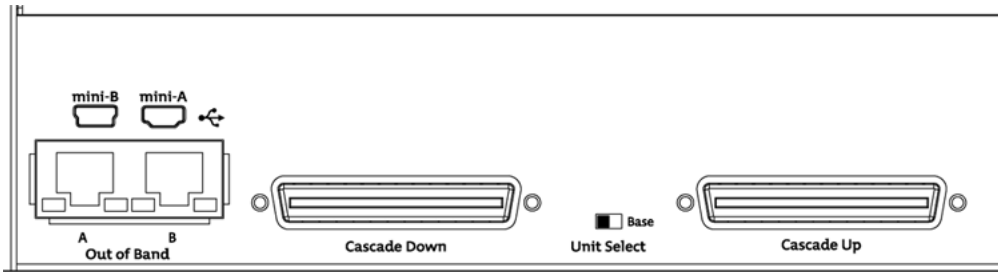

Figure 20: Job aid: 5600 Series stack connector

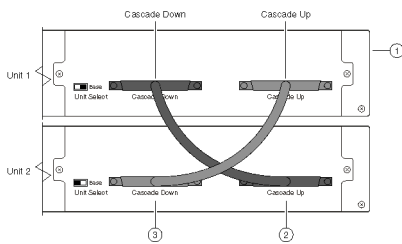

Figure 21: Connecting cascade cables

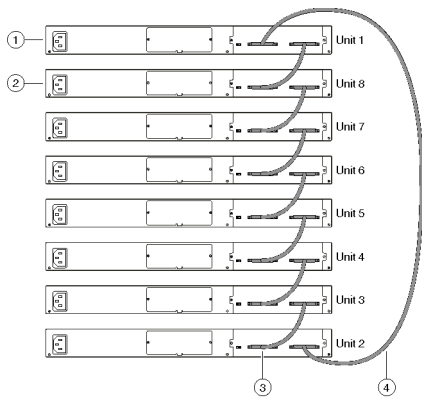

Figure 22: Cascade up stack configuration

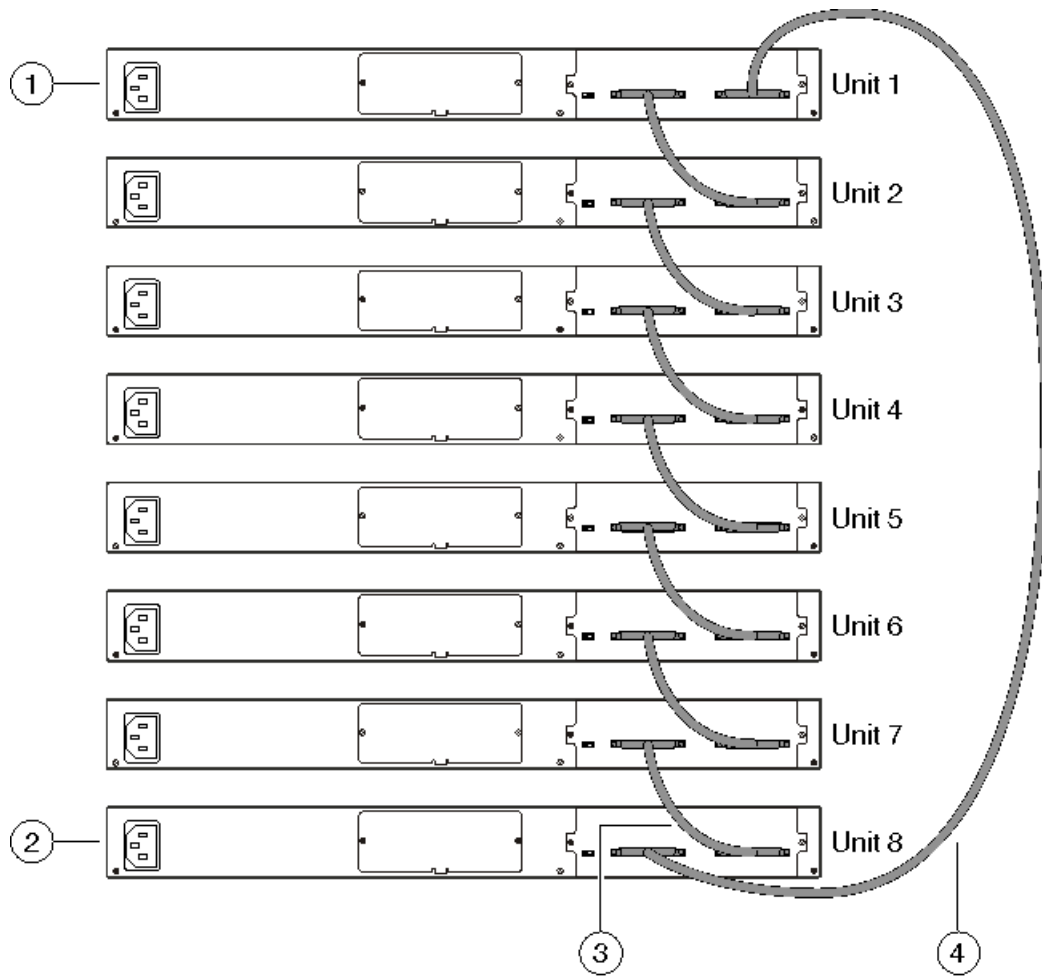

Figure 23: Cascade down stack configuration

Selecting a base unit

About this task

This procedure describes the steps to select a base unit.

Procedure

1. Determine which unit will be the base unit.
2. Locate the Unit Select switch on the rear panel.
3. Slide the switch to the right to designate it as the base unit.

Selecting a base unit using the UI/Mode Select button

About this task

This procedure describes the steps necessary to set the base unit using the UI button.

*** Note:**

The UI button is labeled **Mode Select** on Avaya branded equipment.

Procedure

1. Press and hold the UI button for three seconds. The unit is now in configuration mode. The color and status of the Status LED turns to blinking green.
 2. Press the UI button once. The Base LED is illuminated and the Up and Down LEDs are off to indicate that the button press was recognized.
 3. Press and hold the UI button for three seconds to confirm the command. The Status LED returns to a steady green state to confirm command acceptance. If the command is rejected, the Status LED moves to a blinking amber state.
-

Setting non-base units

About this task

The following procedure describes the steps to set the units as non-base switches.

Procedure

Set the Unit Select switch set to the left to designate them as non-base units.

Setting non-base units using the UI/Mode Select button

About this task

This procedure describes the steps necessary to set a non-base unit using the UI button.

*** Note:**

The UI button is labeled **Mode Select** on Avaya branded equipment.

Procedure

1. Press and hold the UI button for three seconds. The unit is now in configuration mode. The color and status of the Status LED turns to blinking green.

2. Press the UI button twice. The Base LED will turn off and the Up and Down LEDs are turned off.
 3. Press and hold the UI button for three seconds to confirm the commands. The Status LED returns to a steady green state to confirm command acceptance. If the command is rejected, the Status LED moves to a blinking amber state.
-

Resetting a stack using the UI/Mode Select button

About this task

The following procedure describes the steps to reset the stack using the UI button.

*** Note:**

The UI button is labeled **Mode Select** on Avaya branded equipment.

Procedure

1. Press and hold the UI button for three seconds.
The unit is now in configuration mode. The color and status of the Status LED turns to blinking green.
 2. Press the UI button three times.
The Base, Up, and Down LEDs will move to a blinking amber state and blink in unison.
 3. Press and hold the UI button for three seconds to confirm the command.
-

Hybrid stack recommendations and limitation

About this task

Recommendations:

- The 5600 must be a base unit.
- 5600s must be adjacent.
- For 5600 to 5600, use the new stack cables (blue cables).
- For 5600 to 5500, use either the new stack cables (blue cables) or the old ones.

Limitation:

When stacking a 5632FD with any 5500 model, the last two 10gBE ports (31 and 32) of all 5632s are disabled (you do not see port 31 and 32 on the show tech). This limitation only exists in Hybrid Stacks, and is regardless of whether 5632s are adjacent to other 5632s or 5500s.

Chapter 7: Common procedures

About this task

This module contains procedures that are common to more than one product line.

Abandoning a command

About this task

This procedure describes how to abandon a command entered using the UI/Mode Select button.

*** Note:**

The UI button is labeled **Mode Select** on Avaya branded equipment.

Abandoning a command entered using the UI/Mode Select button

Procedure

1. Do not confirm a command within approximately twenty seconds after you enter the command and the system ignores the input.
2. Press the UI/Mode Select button nine or more times to exit configuration mode.

*** Note:**

Wait sixty seconds after the last configuration change before resetting the unit. The system can take up to this long to save configuration changes to the NVRAM. Stacks can be reset immediately after the last configuration change without any loss of information.

Chapter 8: Installation reference

About this task

The following modules provide reference information for the Avaya Ethernet Routing Switches.

- [Power specifications](#) on page 98

RJ-45 connector pin assignments

The following section outlines the connector pin assignments for the RJ-45 connectors in the Avaya Ethernet Routing Switch 5500 Series switches.

Avaya Ethernet Routing Switch 5510 and 5530

The following table outlines the RJ-45 connector pin assignments in the Avaya Ethernet Routing Switch 5510, 5530, and 5600 Series non-PoE switches.

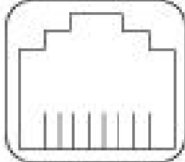
Connector	Pin Number	Signal for 10/100Base-T MDI configuration	Signal for 10/100Base-T MDI-X configuration
 87654321	1	Output transmit data + (TX+)	Input receive data + (RX+)
	2	Output transmit data - (TX-)	Input receive data - (RX-)
	3	Input receive data + (RX+)	Output transmit data + (TX+)
	6	Input receive data + (RX+)	Output transmit data + (TX+)
	4, 5, 7, 8	Not used	Not used
	Pin Number	Signal for 1GBase-T MDI configuration	Signal for 1GBase-T MDI-X configuration
	1	TP0+	TP1+
	2	TP0-	TP1-
	3	TP1+	TP0+
	4	TP2+	TP3+

Connector	Pin Number	Signal for 10/100Base-T MDI configuration	Signal for 10/100Base-T MDI-X configuration
	5	TP2-	TP3-
	6	TP1-	TP0-
	7	TP3+	TP2+
	8	TP3-	TP2-

Console port pin assignments

The following section outlines the console port pin assignments in the Avaya Ethernet Routing Switch 5500 Series.

Table 17: Console port pin assignments

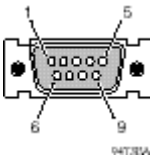

Connector	Pin number	Signal
	1	Carrier detect (not used)
	2	Transmit Data (TXD)
	3	Receive Data (RXD)
	4	Data terminal ready (not used)
	5	Signal ground (GND)
	6	Not used
	7	Request to send (not used)
	8	Not used
	9	Ring indicator (not used)

AC power cord specifications

The following section outlines the AC power cord specifications for various countries. Ensure that you use the correct cord for your location.

Table 18: International power cord specifications

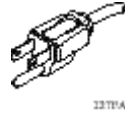
Country / Plug Specification	Specifications	Typical Plug
Continental Europe: • CEE7 standard VII male plug • Harmonized cord (HAR marking on the outside of the cord jacket to	• 220 or 230 VAC • 50 Hz • Single Phase	

Country / Plug Specification	Specifications	Typical Plug
comply with the CENELEC Harmonized Document HD-21)		
United States of America / Canada / Japan: <ul style="list-style-type: none"> • NEMA5-15P male plug • UL-recognized (UL stamped on cord jacket) • CSA-certified (CSA label secured to the cord) 	<ul style="list-style-type: none"> • 100 or 120 VAC • 50 - 60 Hz • Single Phase 	
United Kingdom: <ul style="list-style-type: none"> • BS1363 male plug with fuse • Harmonized cord 	<ul style="list-style-type: none"> • 240 VAC • 50 Hz • Single Phase 	
Australia: <ul style="list-style-type: none"> • AS3112-1981 male plug 	<ul style="list-style-type: none"> • 240 VAC • 50 Hz • Single Phase 	

Avaya Ethernet Routing Switch 5520-24T-PWR and 5520-48T-PWR

The following table outlines the RJ-45 connector pin assignments in the Avaya Ethernet Routing Switch 5510, 5530, and 5600 Series PoE switches.

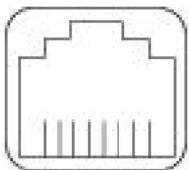
Connector	Pin Number	Signal for 10/100Base-T MDI configuration	Signal for 10/100Base-T MDI-X configuration
 87654321	1	RX+/power+	Receive Data+/power+
	2	RX-/power+	Receive Data-/power+
	3	TX+/power-	Transmit Data+/power-
	4	Not applicable	Not applicable
	5	Not applicable	Not applicable

Connector	Pin Number	Signal for 10/100Base-T MDI configuration	Signal for 10/100Base-T MDI-X configuration
	6	TX-/power-	Transmit Data-/power-
	7	Not applicable	Not applicable
	8	Not applicable	Not applicable

Power specifications

This module describes the power specifications for the power supplies in the 5500 Series.

- [Avaya Ethernet Power Supply 10 power specification](#) on page 98
- [Avaya Ethernet Redundant Power Supply 15 power specification](#) on page 98
- [Avaya Ethernet DC-DC converter module](#) on page 99

Avaya Ethernet Power Supply 10 power specification

The following table shows the power specifications for the Avaya Ethernet Redundant Power Supply 10 (RPS 10).

Table 19: DC power specifications

Output current	4.2 A maximum
Output voltage	-48 VDC
Output power	200 W maximum

Avaya Ethernet Redundant Power Supply 15 power specification

The following table shows the power specifications for the Avaya Ethernet Redundant Power Supply 15 (RPS 15).

Table 20: DC power specifications

Input voltage	100 to 240 VAC 50/60 Hz
Input current	10 A maximum
Inrush current	40 A maximum (regardless of ambient temperature)

Output current	12.0 A
Output voltage	47.5 VDC
Output power	600 W

Avaya Ethernet DC-DC converter module

This module describes where to find the power specifications for the Avaya Ethernet DC-DC converter module.

The Ethernet Routing Switch 5510 requires an additional DC-DC converter module to use the Avaya Ethernet Routing Switch Redundant Power Supply Model 15 (RPS 15). This module connects the RPS 15 to the Ethernet Routing Switch 5510 but is not required for other switches in the 5500 Series.

For information on connecting this module to the 5510, see DC-DC Converter Module for the Baystack 5000 Series Switch, 215081-A.

Chapter 9: Customer Service

Visit the Avaya Web site to access the complete range of services and support that Avaya provides. Go to www.avaya.com or go to one of the pages listed in the following sections.

Navigation

- [Getting technical documentation](#) on page 101
- [Getting product training](#) on page 101
- [Getting help from a distributor or reseller](#) on page 101
- [Getting technical support from the Avaya Web site](#) on page 102

Getting technical documentation

To download and print selected technical publications and release notes directly from the Internet, go to www.avaya.com/support.

Getting product training

Ongoing product training is available. For more information or to register, you can access the Web site at www.avaya.com/support. From this Web site, you can locate the Training contacts link on the left-hand navigation pane.

Getting help from a distributor or reseller

If you purchased a service contract for your Avaya product from a distributor or authorized reseller, contact the technical support staff for that distributor or reseller for assistance.

Getting technical support from the Avaya Web site

The easiest and most effective way to get technical support for Avaya products is from the Avaya Technical Support Web site at www.avaya.com/support.