



KRAMER ELECTRONICS LTD.

# USER MANUAL

MODELS:

**KW-11T**

Wireless High Definition Transmitter

**KW-11R**

Wireless High Definition Receiver

# KW-11T, KW-11R Quick Start Guide



This guide helps you install and use your product for the first time. For more detailed information, go to [http://www.kramerelectronics.com/support/product\\_downloads.asp](http://www.kramerelectronics.com/support/product_downloads.asp) to download the latest manual or scan the QR code on the left.

## Step 1: Check what's in the box

- KW-11T, KW-11R** Wireless High Definition Transmitter and Receiver
- USB Power Adapter
- Power adapter 5V DC
- KW-11R** Stand
- Quick Start Guide
- USB to Mini USB Power Cable

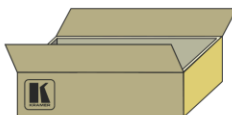

Save the original box and packaging materials in case your Kramer product needs to be returned to the factory for service.

## Step 2: Connect the input and output

Always switch off the power to all devices before connecting your **KW-11T** and **KW-11R**.

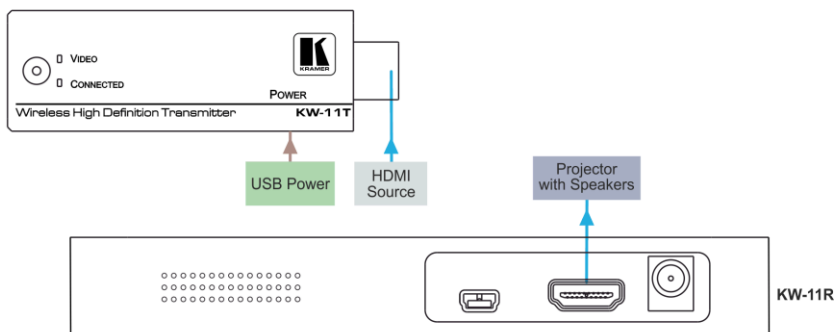

For best results, we recommend that you always use Kramer high-performance cables when connecting AV equipment to the **KW-11T, KW-11R**.

## Step 3: Connect the power



Connect the USB power cable from the DVD player/laptop to the **KW-11T**. Connect the power adapter to the **KW-11R** and plug the adapter into the mains electricity or the supplied USB cable to either the laptop or to the **VP-81SID** equipped with a USB power port.

# Contents

<b>1</b>	<b>Introduction</b>	<b>1</b>
<b>2</b>	<b>Getting Started</b>	<b>2</b>
2.1	Achieving the Best Performance	2
2.2	Recycling Kramer Products	3
2.3	Accessory to Medical Equipment (IEC 60601-1)	3
<b>3</b>	<b>Overview</b>	<b>4</b>
<b>4</b>	<b>Defining the KW-11T/KW-11R Line Transmitter and Receiver</b>	<b>5</b>
4.1	Defining the KW-11T Wireless High Definition Transmitter	5
4.2	Defining the KW-11R Wireless High Definition Receiver	6
<b>5</b>	<b>Connecting the KW-11T and KW-11R</b>	<b>7</b>
5.1	Connecting the KW-11T and KW-11R	7
<b>6</b>	<b>Frequently Asked Questions</b>	<b>9</b>
<b>7</b>	<b>Technical Specifications</b>	<b>10</b>
7.1	Supported Video Formats	11
7.2	KW-11T Mini USB Pinout	11
<b>8</b>	<b>FCC Radio Frequency Interference Statement</b>	<b>12</b>

## Figures

Figure 1:	KW-11T Wireless High Definition Transmitter Top and Side Panels	5
Figure 2:	KW-11R Wireless High Definition Receiver Front and Rear Panels	6
Figure 3:	Connecting the KW-11T and KW-11R	7
Figure 4:	KW-11T Mini USB Pinout	11

---

# 1 Introduction

Welcome to Kramer Electronics! Since 1981, Kramer Electronics has been providing a world of unique, creative, and affordable solutions to the vast range of problems that confront video, audio, presentation, and broadcasting professionals on a daily basis. In recent years, we have redesigned and upgraded most of our line, making the best even better!

Our 1,000-plus different models now appear in 14 groups that are clearly defined by function: GROUP 1: Distribution Amplifiers; GROUP 2: Switchers and Routers; GROUP 3: Control Systems; GROUP 4: Format/Standards Converters; GROUP 5: Range Extenders and Repeaters; GROUP 6: Specialty AV Products; GROUP 7: Scan Converters and Scalers; GROUP 8: Cables and Connectors; GROUP 9: Room Connectivity; GROUP 10: Accessories and Rack Adapters and GROUP 11: Sierra Video Products; GROUP 12: Digital Signage; and GROUP 13: Audio, and GROUP 14: Collaboration.

Thank you for purchasing the Kramer **KW-11T** *Wireless High Definition Transmitter* and DigiTOOLS® **KW-11R** *Wireless High Definition Receiver* which are ideal for:

- Home theater
- Presentation and multimedia applications
- Short range video and audio distribution

---

## 2 Getting Started

We recommend that you:

- Unpack the equipment carefully and save the original box and packaging materials for possible future shipment
- Review the contents of this user manual



Go to [www.kramerav.com/downloads/KW-11](http://www.kramerav.com/downloads/KW-11) to check for up-to-date user manuals, application programs, and to check if firmware upgrades are available (where appropriate).

### 2.1 Achieving the Best Performance

To achieve the best performance:

- Use only good quality connection cables (we recommend Kramer high-performance, high-resolution cables) to avoid interference, deterioration in signal quality due to poor matching, and elevated noise levels (often associated with low quality cables)
- Always mount the **KW-11R** vertically using the supplied stand
- Do not place objects next to the **KW-11T** transmitter or **KW-11R** receiver
- Do not secure the cables in tight bundles or roll the slack into tight coils
- Avoid interference from neighboring electrical appliances that may adversely influence signal quality
- Position your Kramer **KW-11T** and **KW-11R** away from moisture, excessive sunlight and dust



This equipment is to be used only inside a building. It may only be connected to other equipment that is installed inside a building

## 2.2 Recycling Kramer Products

The Waste Electrical and Electronic Equipment (WEEE) Directive 2002/96/EC aims to reduce the amount of WEEE sent for disposal to landfill or incineration by requiring it to be collected and recycled. To comply with the WEEE Directive, Kramer Electronics has made arrangements with the European Advanced Recycling Network (EARN) and will cover any costs of treatment, recycling and recovery of waste Kramer Electronics branded equipment on arrival at the EARN facility. For details of Kramer's recycling arrangements in your particular country go to our recycling pages at [www.kramerav.com/support/recycling](http://www.kramerav.com/support/recycling).

## 2.3 Accessory to Medical Equipment (IEC 60601-1)

In the modern medical environment remote access is essential, for example, to transfer clinical data between doctors and to train to medical students. Both the **KW-11T** and **KW-11R** are certified according to the IEC 60601-1-2, Clause 2.1.3, Medical Electrical Equipment, Part 1: General Requirements for EMC standard which is required when accessory devices are used at locations where medical personnel and patients are present.

The **KW-11T** and **KW-11R** constitute an optional component that can be considered necessary and suitable as part of medical equipment or for use as part of a medical system to provide real time simultaneous video feeds to those present at the local medical environment and at remote locations. In this environment, the **KW-11T** and **KW-11R** can be added to the system ONLY if the connecting equipment has been evaluated and meets the IEC 60601-1-2 EMC standards. Note, that when attaching accessory devices to a digital or analog interface, they must comply with the IEC standard for which they are used: for EMC Standard (IEC 60601-1-2), Information Technology equipment (IEC 60950-1 (2ed)).

---

## 3 Overview

The **KW-11T** and **KW-11R** is a high-definition, wireless, HDMI transmitter and receiver combination for indoor use over short range distances.

The **KW-11T** converts an HDMI signal into a wireless signal. The **KW-11R** converts the wireless signal back into HDMI.

The **KW-11T** and **KW-11R** support:

- Uncompressed video resolutions up to 1080p @60Hz
- Zero latency
- EDID
- HDCP
- CEC
- OSD (On Screen Display)
- Secure link using AES-128 bit encryption
- A transmission range of up to 12m (39ft)
- Medical equipment compliance requirements

## 4 Defining the KW-11T/KW-11R Line Transmitter and Receiver

This section defines the:

- **KW-11T** *Wireless High Definition Transmitter* (see [Section 4.1](#))
- **KW-11R** *Wireless High Definition Receiver* (see [Section 4.2](#))

### 4.1 Defining the KW-11T Wireless High Definition Transmitter

The **KW-11T** encodes an HDMI signal and transmits it uncompressed and without delay over a wireless link to the **KW-11R** receiver. [Figure 1](#) defines the top and side panels of the **KW-11T**.

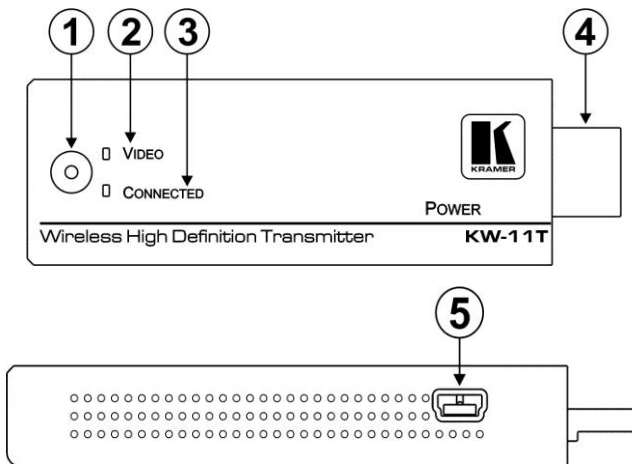

Figure 1: KW-11T Wireless High Definition Transmitter Top and Side Panels

#	Feature	Function
1	Code Button	For factory use only
2	VIDEO LED	Lights green when there is a valid HDMI input signal
3	CONNECTED LED	Indicates the following: <ul style="list-style-type: none"> <li>• Lights blue when there is a wireless connection to the receiver</li> <li>• Does not light when there is no connection</li> <li>• Flashes to indicate a device fault</li> </ul>
4	HDMI Input Connector	Connect to the HDMI source (see <a href="#">Section 5</a> )
5	POWER Mini-USB Connector	Connect to the supplied 5V DC USB power adapter



## 4.2 Defining the KW-11R Wireless High Definition Receiver

The **KW-11R** receives the wireless signal from the Kramer **KW-11T** and converts it into an HDMI output.

[Figure 2](#) defines the front and rear panels of the **KW-11R**.

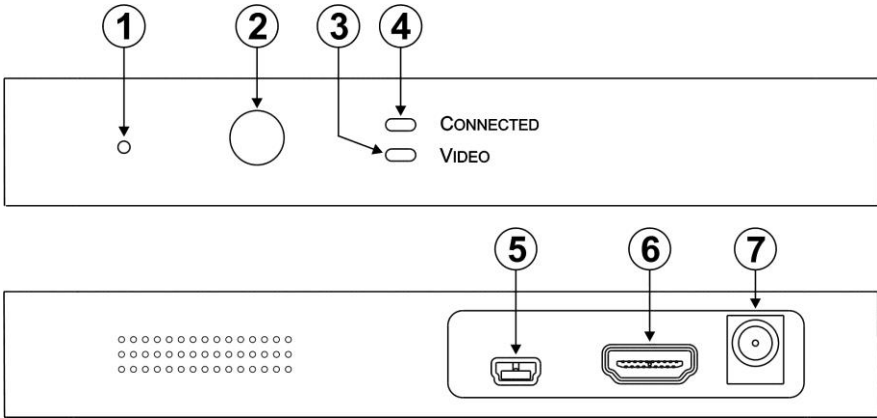

Figure 2: KW-11R Wireless High Definition Receiver Front and Rear Panels

#	Feature	Function
1	Code Button	For factory use only
2	Infrared Receiver Window	For factory use only
3	VIDEO LED	Lights green when there is a valid HDMI signal
4	CONNECTED LED	Indicates the following: <ul style="list-style-type: none"> <li>• Lights green when there is a wireless connection to the transmitter</li> <li>• Does not light when there is no connection</li> <li>• Flashes to indicate a device fault</li> </ul>
5	USB Connector	For the use of Kramer service personnel only
6	HDMI OUT Connector	Connect to the HDMI acceptor (see <a href="#">Section 5</a> )
7	POWER Connector	Connect to the supplied +5V DC power adapter. Center pin positive

## 5 Connecting the KW-11T and KW-11R



Always switch off the power to all devices before connecting your KW-11T and KW-11R.

### 5.1 Connecting the KW-11T and KW-11R

**Note:** For best performance always mount the KW-11R receiver vertically using the supplied stand.

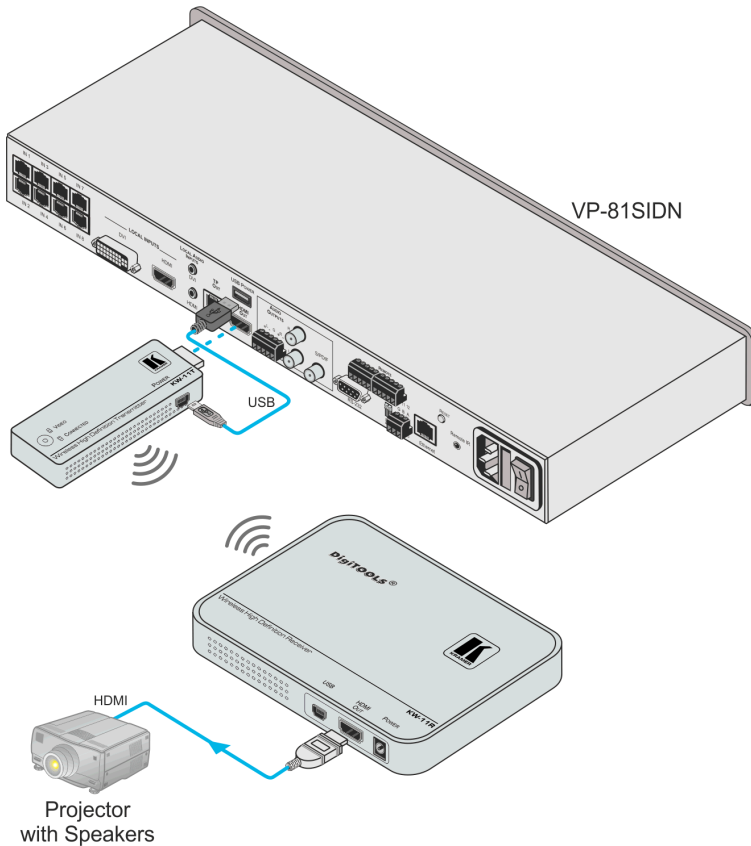

Figure 3: Connecting the KW-11T and KW-11R

**Note:** The HDCP status of the **KW-11** follows that of the device connected to its output.

**To connect the KW-11T and the KW-11R as illustrated in the example in [Figure 3](#):**

1. On the **KW-11T** connect:
  - The HDMI source (for example, a **VP-81SIDN** or laptop computer) to the HDMI connector
  - The USB Power port on the **VS-81SIDN** to the Power port on the **KW-11T** using the supplied USB power cable
2. On the **KW-11R** connect:
  - The HDMI Out connector to the HDMI acceptor (for example, a projector with speakers)
  - The power adapter to the Power connector and plug the power adapter into a mains power socket

---

## 6 Frequently Asked Questions

Q: How many **KW-11T/KW-11R** pairs can I use in same room?

A: Up to three.

**Note:** Limited to two in Japan and Israel due to frequency limitations.

Q: What restrictions are there when using multiple **KW-11T/KW-11R** pairs in the same room?

A: Two devices should be no closer to one another than 50cm (20in).

Q: Can I use a USB extender cable?

A: Yes, up to 5m (16ft) long.

Q: Can I use multiple **KW-11R** receivers with one **KW-11T** transmitter?

A: No, the **KW-11T/KW-11R** are point-to-point devices.

## 7 Technical Specifications

	KW-11T	KW-11R
INPUT:	1 HDMI plug on an HDMI connector	Internal antenna
OUTPUT:	Internal antenna	1 HDMI on an HDMI connector
VIDEO RESOLUTION:	Up to SXGA, 1080p (for specific resolutions, see Supported Video Formats below)	
AUDIO FORMATS:	AC3, DTS, Dolby Digital, 2 Channels PCM up to 96Khz	
AUDIO RATE:	Digital audio from the HDMI input up to 6Mb/s	
TRANSMISSION POWER:	<18dBm conducted	<12dBm per channel conducted
RECEIVING SENSITIVITY:	-75dBm	-65dBm
SYSTEM LATENCY:	<1ms	
RF COMMUNICATION FREQUENCY:	5.19 ~ 5.9GHz (In Japan and Israel operation is limited to the lower bands; 5.15 to 5.25GHz)	
UNOBSTRUCTED TRANSMISSION RANGE:	12m (39ft)	12m (39ft)
POWER CONSUMPTION:	5V DC 900mA	5V DC 1.6A
OPERATING TEMPERATURE:	0° to +40°C (32° to 104°F)	
STORAGE TEMPERATURE:	-40° to +70°C (-40° to 158°F)	
HUMIDITY:	10% to 90%, RHL non-condensing	
DIMENSIONS:	9.8cm x 2.9cm x 1.5cm (3.86" x 1.14" x 0.59") W, D, H	14.8cm x 9.7cm x 1.8cm (5.83" x 3.82" x 0.71") W, D, H
WEIGHT:	0.48kg (1.1lbs.) approx. each	
INCLUDED ACCESSORIES:	USB power supply 5V DC 2A, Power supply 5V DC 2A, HDMI cable, receiver stand, Mini USB to USB power cable	

The **KW-11T** and **KW-11R** are wireless devices and are subject to wireless certification restrictions. They are currently certified for use in various countries including the US and EU. Consult your local sales office for details regarding certification in your country.

## 7.1 Supported Video Formats

**Note:** The Connected LED flashes to indicate that the input video rate being received is not supported.

Video Format Timings	Resolution
<b>Primary CEV Video Timing</b>	
640x480p @ 59.94 / 60Hz	480p
720x480p @ 59.94Hz	
720x480p @ 60Hz	
720x576p @ 50Hz	576p
1280x720p @ 50Hz	720p
1280x720p @ 59.94 / 60Hz	
1920x1080i @ 50Hz	1080i
1920x1080i @ 59.94 / 60Hz	
1920x1080p @ 50Hz	1080p / 60
1920x1080p @ 59.94 / 60Hz	
<b>Secondary CEV Video Timing</b>	
1920x1080p @ 23.98 / 24Hz	1080p / 24
1920x1080p @ 25Hz	
1920x1080p @ 29.97 / 30Hz	
<b>VESA Timing (DVI Only)</b>	
640x480 @ 59.94 / 72.809Hz	VGA
800x600 @ 60.317 / 72.188Hz	SVGA
1024x768 @ 60 / 70.069Hz	XGA
1280x768 @ 60Hz	WXGA
1280x1024 @ 60Hz	SXGA

## 7.2 KW-11T Mini USB Pinout



Figure 4: KW-11T Mini USB Pinout

USB Pin Number	Description
1	+5V
2	Do not connect
3	Do not connect
4	Do not connect
5	0V Ground

---

## 8 FCC Radio Frequency Interference Statement

This equipment has been tested and found to comply with the limits for a Class B digital device, pursuant to part 15 of the FCC Rules. These limits are designed to provide reasonable protection against harmful interference in a residential installation. This equipment generates uses and can radiate radio frequency energy and, if not installed and used in accordance with the instructions, may cause harmful interference to radio communications. However, there is no guarantee that interference will not occur in a particular installation. If this equipment does cause harmful interference to radio or television reception, which can be determined by turning the equipment off and on, the user is encouraged to try to correct the interference by one or more of the following measures:

- Reorient or relocate the receiving antenna
- Increase the separation between the equipment and receiver
- Connect the equipment into an outlet on a circuit different from that to which the receiver is connected
- Consult the dealer or an experienced radio/TV technician for help

Kramer Electronics is not responsible for any radio or communication interference caused by using other than specified or recommended cables and battery or by unauthorized changes or modifications to this equipment. Changes or modifications not expressly approved by the manufacturer could void the user's authority to operate the equipment.

This device complies with part 15 of the FCC Rules. Operation is subject to the following two conditions:

1. This device may not cause harmful interference,  
–and–
2. This device must accept any interference received, including interference that may cause undesired operation.

The warranty obligations of Kramer Electronics Inc. ("Kramer Electronics") for this product are limited to the terms set forth below:

**What is Covered**

This limited warranty covers defects in materials and workmanship in this product.

**What is Not Covered**

This limited warranty does not cover any damage, deterioration or malfunction resulting from any alteration, modification, improper or unreasonable use or maintenance, misuse, abuse, accident, neglect, exposure to excess moisture, fire, improper packing and shipping (such claims must be presented to the carrier), lightning, power surges, or other acts of nature. This limited warranty does not cover any damage, deterioration or malfunction resulting from the installation or removal of this product from any installation, any unauthorized tampering with this product, any repairs attempted by anyone unauthorized by Kramer Electronics to make such repairs, or any other cause which does not relate directly to a defect in materials and/or workmanship of this product. This limited warranty does not cover cartons, equipment enclosures, cables or accessories used in conjunction with this product.

Without limiting any other exclusion herein, Kramer Electronics does not warrant that the product covered hereby, including, without limitation, the technology and/or integrated circuit(s) included in the product, will not become obsolete or that such items are or will remain compatible with any other product or technology with which the product may be used.

**How Long this Coverage Lasts**

The standard limited warranty for Kramer products is seven (7) years from the date of original purchase, with the following exceptions:

1. All Kramer VIA products are covered by a standard three (3) year warranty for VIA hardware and a standard one (1) year warranty for firmware and software updates. (An extended software warranty plan for an additional 2 years can be purchased separately).
2. All Kramer fiber optic cables and adapters, all Kramer speakers and Kramer touch panels are covered by a standard one (1) year warranty.
3. All Kramer Cobra products, all Kramer Calibre products, all Kramer Minicom digital signage products, all HighSecLabs products, all streaming, and all wireless products are covered by a standard three (3) year warranty.
4. All Sierra Video MultiViewers are covered by a standard five (5) year warranty.
5. Sierra switchers & control panels are covered by a standard seven (7) year warranty (excluding power supplies and fans that are covered for three (3) years).
6. K-Touch software is covered by a standard one (1) year warranty for software updates.
7. All Kramer passive cables are covered by a ten (10) year warranty.

**Who is Covered**

Only the original purchaser of this product is covered under this limited warranty. This limited warranty is not transferable to subsequent purchasers or owners of this product.

**What Kramer Electronics Will Do**

Kramer Electronics will, at its sole option, provide one of the following three remedies to whatever extent it shall deem necessary to satisfy a proper claim under this limited warranty:

1. Elect to repair or facilitate the repair of any defective parts within a reasonable period of time, free of any charge for the necessary parts and labor to complete the repair and restore this product to its proper operating condition. Kramer Electronics will also pay the shipping costs necessary to return this product once the repair is complete.
2. Replace this product with a direct replacement or with a similar product deemed by Kramer Electronics to perform substantially the same function as the original product.
3. Issue a refund of the original purchase price less depreciation to be determined based on the age of the product at the time remedy is sought under this limited warranty.

**What Kramer Electronics Will Not Do Under This Limited Warranty**

If this product is returned to Kramer Electronics or the authorized dealer from which it was purchased or any other party authorized to repair Kramer Electronics products, this product must be insured during shipment, with the insurance and shipping charges prepaid by you. If this product is returned uninsured, you assume all risks of loss or damage during shipment. Kramer Electronics will not be responsible for any costs related to the removal or re-installation of this product from or into any installation. Kramer Electronics will not be responsible for any costs related to any setting up this product, any adjustment of user controls or any programming required for a specific installation of this product.

**How to Obtain a Remedy Under This Limited Warranty**

To obtain a remedy under this limited warranty, you must contact either the authorized Kramer Electronics reseller from whom you purchased this product or the Kramer Electronics office nearest you. For a list of authorized Kramer Electronics resellers and/or Kramer Electronics authorized service providers, visit our web site at [www.kramerav.com](http://www.kramerav.com) or contact the Kramer Electronics office nearest you.

In order to pursue any remedy under this limited warranty, you must possess an original, dated receipt as proof of purchase from an authorized Kramer Electronics reseller. If this product is returned under this limited warranty, a return authorization number, obtained from Kramer Electronics, will be required (RMA number). You may also be directed to an authorized reseller or a person authorized by Kramer Electronics to repair the product.

If it is decided that this product should be returned directly to Kramer Electronics, this product should be properly packed, preferably in the original carton, for shipping. Cartons not bearing a return authorization number will be refused.

**Limitation of Liability**

THE MAXIMUM LIABILITY OF KRAMER ELECTRONICS UNDER THIS LIMITED WARRANTY SHALL NOT EXCEED THE ACTUAL PURCHASE PRICE PAID FOR THE PRODUCT. TO THE MAXIMUM EXTENT PERMITTED BY LAW, KRAMER ELECTRONICS IS NOT RESPONSIBLE FOR DIRECT, SPECIAL, INCIDENTAL OR CONSEQUENTIAL DAMAGES RESULTING FROM ANY BREACH OF WARRANTY OR CONDITION, OR UNDER ANY OTHER LEGAL THEORY. Some countries, districts or states do not allow the exclusion or limitation of relief, special, incidental, consequential or indirect damages, or the limitation of liability to specified amounts, so the above limitations or exclusions may not apply to you.

**Exclusive Remedy**

TO THE MAXIMUM EXTENT PERMITTED BY LAW, THIS LIMITED WARRANTY AND THE REMEDIES SET FORTH ABOVE ARE EXCLUSIVE AND IN LIEU OF ALL OTHER WARRANTIES, REMEDIES AND CONDITIONS, WHETHER ORAL OR WRITTEN, EXPRESS OR IMPLIED. TO THE MAXIMUM EXTENT PERMITTED BY LAW, KRAMER ELECTRONICS SPECIFICALLY DISCLAIMS ANY AND ALL IMPLIED WARRANTIES, INCLUDING, WITHOUT LIMITATION, WARRANTIES OF MERCHANTABILITY AND FITNESS FOR A PARTICULAR PURPOSE. IF KRAMER ELECTRONICS CANNOT LAWFULLY DISCLAIM OR EXCLUDE IMPLIED WARRANTIES UNDER APPLICABLE LAW, THEN ALL IMPLIED WARRANTIES COVERING THIS PRODUCT, INCLUDING WARRANTIES OF MERCHANTABILITY AND FITNESS FOR A PARTICULAR PURPOSE, SHALL APPLY TO THIS PRODUCT AS PROVIDED UNDER APPLICABLE LAW.

IF ANY PRODUCT TO WHICH THIS LIMITED WARRANTY APPLIES IS A "CONSUMER PRODUCT" UNDER THE MAGNUSON-MOSS WARRANTY ACT (15 U.S.C.A. §2001, ET SEQ.) OR OTHER APPLICABLE LAW, THE FOREGOING DISCLAIMER OF IMPLIED WARRANTIES SHALL NOT APPLY TO YOU, AND ALL IMPLIED WARRANTIES ON THIS PRODUCT, INCLUDING WARRANTIES OF MERCHANTABILITY AND FITNESS FOR THE PARTICULAR PURPOSE, SHALL APPLY AS PROVIDED UNDER APPLICABLE LAW.

**Other Conditions**

This limited warranty gives you specific legal rights, and you may have other rights which vary from country to country or state to state.

This limited warranty is void if (i) the label bearing the serial number of this product has been removed or defaced, (ii) the product is not distributed by Kramer Electronics or (iii) this product is not purchased from an authorized Kramer Electronics reseller. If you are unsure whether a reseller is an authorized Kramer Electronics reseller, visit our web site at [www.kramerav.com](http://www.kramerav.com) or contact a Kramer Electronics office from the list at the end of this document.

Your rights under this limited warranty are not diminished if you do not complete and return the product registration form or complete and submit the online product registration form. Kramer Electronics thanks you for purchasing a Kramer Electronics product. We hope it will give you years of satisfaction





For the latest information on our products and a list of Kramer distributors, visit our Web site where updates to this user manual may be found.

**We welcome your questions, comments, and feedback.**

Web site: [www.kramerav.com](http://www.kramerav.com)

E-mail: [info@kramerel.com](mailto:info@kramerel.com)

CE



**SAFETY WARNING**

Disconnect the unit from the power supply before opening and servicing



P/N: 2900-300194



Rev: 9