



Mezzo Series

Serie Mezzo / Mezzo-Serie / Mezzo Série
Serie Mezzo / Série Mezzo
Mezzo سلسله / Mezzo シリーズ /
Mezzo系列

USER GUIDE

GUIDA UTENTE / BENUTZERHANDBUCH / MODE D'EMPLOI
GUÍA DEL USUARIO / GUIA DE USARIO
مذخت سمل لىلد / यूज़र-गइड
快速指南

Mezzo 322, Mezzo 324 A/AD
Mezzo 602, Mezzo 604 A/AD

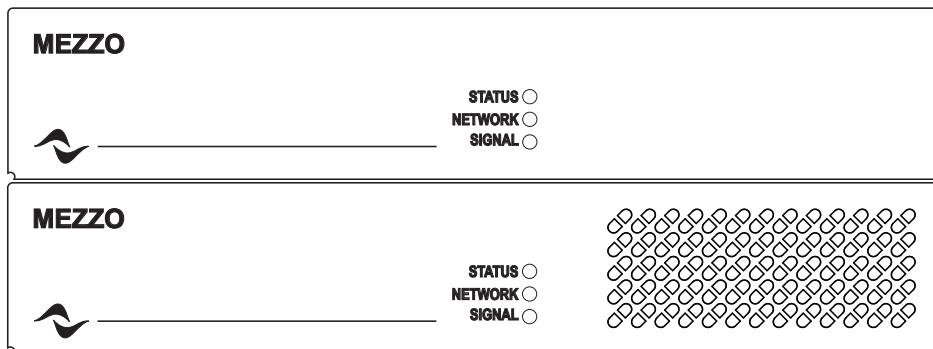

Important Safety Instructions

-  THE TRIANGLE WITH THE LIGHTNING BOLT IS USED TO ALERT THE USER TO THE RISK OF ELECTRIC SHOCK.
-  THE TRIANGLE WITH THE EXCLAMATION POINT IS USED TO ALERT THE USER TO IMPORTANT OPERATING OR MAINTENANCE INSTRUCTIONS.
-  THE CE-MARK INDICATES THE COMPLIANCE OF THE PRODUCT TO ALL THE APPLICABLE EUROPEAN DIRECTIVES
-  SYMBOL FOR EARTH/GROUND CONNECTION.
-  SYMBOL INDICATING THAT THE EQUIPMENT IS FOR INDOOR USE ONLY.
-  SYMBOL FOR CONFORMITY WITH DIRECTIVE 2012/19/EC OF THE EUROPEAN PARLIAMENT ON WASTE ELECTRICAL AND ELECTRONIC EQUIPMENT (WEEE).
-  -10°C TO +45°C DERATING ABOVE 35°C.
-  10% TO 90% HUMIDITY (NON CONDENSING).
-  DO NOT USE THE UNIT AT ALTITUDES ABOVE 2000 M.
-  DO NOT USE THE UNIT IN TROPICAL ENVIRONMENT.
-  WARNING: TO REDUCE THE RISK OF ELECTRIC SHOCK, DO NOT ATTEMPT TO OPEN ANY PART OF THE UNIT. NO USER-SERVICEABLE PARTS INSIDE. REFER SERVICING TO QUALIFIED SERVICE PERSONNEL.
-  CONNECTION TO THE MAINS SHALL BE DONE ONLY BY A ELECTROTECHNICAL SKILLED PERSON ACCORDING THE NATIONAL REQUIREMENTS OF THE COUNTRIES WHERE THE UNIT IS SOLD.
-  DO NOT USE THIS AMPLIFIER IF THE ELECTRICAL POWER CORD IS FRAYED OR BROKEN.
-  TO AVOID ELECTRICAL SHOCK, DO NOT TOUCH ANY EXPOSED SPEAKER WIRING WHILE THE AMPLIFIER IS OPERATING.
-  DO NOT SPILL WATER OR OTHER LIQUIDS INTO OR ON THE AMPLIFIER.
-  NO NAKED FLAME SOURCES SUCH AS LIGHTED CANDLES SHOULD BE PLACED ON THE AMPLIFIER.
-  WARNING TO PREVENT INJURY, THIS APPARATUS MUST BE SECURELY ATTACHED TO THE FLOOR/WALL IN ACCORDANCE WITH THE INSTALLATION INSTRUCTIONS.
-  THIS DEVICE MUST BE POWERED EXCLUSIVELY BY EARTH CONNECTED MAINS SOCKETS IN ELECTRICAL NETWORKS COMPLIANT TO THE IEC 364 OR SIMILAR RULES
-  DISCONNECT THE AC MAINS SOURCE BEFORE ATTEMPTING TO CLEAN ANY PART OF THE AMPLIFIER
-  THE BREAKER NEEDS TO SUPPORT 375 VA PER MEZZO, SO MAX 3 MEZZO PER OUTLET AT 115V 10A, OR MAX 6 MEZZO PER OUTLET WITH 230V 10A
-  IT IS HIGHLY RECOMMENDED TO UNPLUG THE OUTPUT CONNECTORS BEFORE PROCEEDING WITH THE SELF CHECK PROCEDURE
-  THE TESTING SIGNALS MIGHT CAUSE LOUDSPEAKER IMPAIRMENTS.
-  OUTPUT TERMINALS ARE HAZARDOUS: WIRING CONNECTION TO THESE TERMINALS REQUIRES INSTALLATION BY AN INSTRUCTED PERSON AND THE USE OF READY MADE LEADS.
CLASS 2 WIRING
-  PROPERLY FIT THE AC MAINS PLUG TO THE AMPLIFIER INLET. BEFORE POWERING THIS AMPLIFIER, VERIFY THAT THE CORRECT VOLTAGE RATING IS BEING USED.
-  VERIFY THAT YOUR MAINS CONNECTION IS CAPABLE OF SATISFYING THE POWER RATINGS OF THE DEVICE.
-  TAKE CARE TO LOCK THE OUTPUT TERMINAL BEFORE SWITCHING THE DEVICE ON.



CAUTION

RISK OF ELECTRIC SHOCK DO NOT OPEN



This unit has been engineered and manufactured to ensure your personal safety. But IMPROPER USE CAN RESULT IN POTENTIAL ELECTRICAL SHOCK OR FIRE HAZARD.

In order not to defeat the safeguards incorporated into this product, observe the following basic rules for its installation, use and service. Please read these "Important Safeguards" carefully before use.

- Read these instructions.
- Keep these instructions.
- Heed all warnings.
- Follow all instructions.
- Do not use this equipment near water.
- Clean only with a dry cloth.
- Do not block any ventilation openings. Install in accordance with the manufacturer's instructions.
- Do not install near any heat sources such as radiators, heat registers, stoves, or other apparatus that produce heat.
- Do not defeat the safety purpose of the polarized or grounding-type plug. A polarized plug has two blades with one wider than the other. A grounding-type plug has two blades and a third grounding prong. The wide blade or the third prong are provided for your safety. If the provided plug does not fit into your outlet, consult an electrician for replacement of the obsolete outlet.
- Protect the power cord from being walked on or pinched particularly at plugs, convenience receptacles, and the point where they exit from the apparatus.
- Only use attachments/accessories specified by the manufacturer.
- Use only with the cart, stand, tripod, bracket, or table specified by the manufacturer, or sold with the apparatus. When a cart is used, use caution when moving the cart/apparatus combination to avoid injury from tip-over.
- Unplug this apparatus during lightning storms or when unused for long periods of time.
- Refer all servicing to qualified service personnel. Servicing is required when the apparatus has been damaged in any way, such as power-supply cord or plug is damaged, liquid has been spilled or objects have fallen into the apparatus, the apparatus has been exposed to rain or moisture, does not operate normally, or has been dropped.
- The apparatus shall be connected to a MAINS socket outlet with a protective earthing connection
- Where the MAINS plug or an appropriate coupler is used as the disconnect device, the disconnect device shall remain readily operable.



THE MANUFACTURER CANNOT BE HELD RESPONSIBLE FOR DAMAGES CAUSED TO PERSONS, THINGS OR DATA DUE TO AN IMPROPER OR MISSING GROUND CONNECTION.

CONTACT THE AUTHORIZED SERVICE CENTER FOR ORDINARY AND EXTRAORDINARY MAINTENANCE.

IT IS ABSOLUTELY NECESSARY TO VERIFY THESE FUNDAMENTAL REQUIREMENTS OF SAFETY AND, IN CASE OF DOUBT, REQUIRE AN ACCURATE CHECK BY QUALIFIED PERSONNEL.

WEEE Directive

If the time arises to throw away your product, please recycle all possible component.



This symbol indicates that when the end-user wishes to discard this product, it must be sent to separate collection facilities for recovery and recycling. By separating this product from other household-type waste, the volume of waste sent to incinerators or land-fills will be reduced and natural resources will thus be conserved.

The Waste Electrical and Electronic Equipment Directive (WEEE Directive) aims to minimise the impact of electrical and electronic goods on the environment. Powersoft S.p.A. comply with the Directive 2012/19/EU of the European Parliament on waste electrical and electronic equipment (WEEE) in order to reduce the amount of WEEE that is being disposed of in land-fill site.

All of our products are marked with the WEEE symbol; this indicates that this product must NOT be disposed of with other waste. Instead it is the user's responsibility to dispose of their waste electrical and electronic equipment by handing it over to an approved reprocessor, or by returning it to Powersoft S.p.A. for reprocessing. For more information about where you can send your waste equipment for recycling, please contact Powersoft S.p.A. or one of your local distributors.

EC Declaration Of Conformity

Manufacturer:
Powersoft S.p.A.
via E. Conti 5
50018 Scandicci (Fi)
Italy



We declare that under our sole responsibility the products:

Model Names:

MEZZO 322 A
MEZZO 324 A
MEZZO 602 A
MEZZO 604 A
MEZZO 322 AD
MEZZO 324 AD
MEZZO 602 AD
MEZZO 604 AD

Intended use: Professional Audio Amplifier

Are in conformity with the provisions of the following EC Directives, including all amendments, and with national legislation implementing these directives:

2014/35/EU	Low Voltage Directive
2014/30/EU	Electromagnetic Compatibility Directive
2011/65/EU	RoHS Directive

The following harmonized standards are applied:

EN 55032: 2012
EN 55035: 2017
EN 60065: 2014 /AC: 2016

Scandicci,
September 2019

Luca Lastrucci
Managing Director

For compliance questions only: compliance@powersoft.it

Preliminary operations

Package list

The box contains the following:

- 1 Mezzo amplifier
- Block connectors
- 2 Bracket A
- 2 Bracket B
- 2 screws (for attaching the brackets)
- Mains power cable
- 1 L-shaped T8 key
- 1 plug retain bracket
- 1 wall mount template sheet

Location

Install your amplifier in a location that allows some exchange of air. Amplifier comes with mounting accessories for the following mounting options:

On a shelf – The rubber feet allow you to set your amplifier on any flat surface.

Custom mount – It's possible to custom design fittings for poles and other applications, using screws fitting the threaded holes in the amplifier. These screws must not be longer than 8 mm. The safest way to avoid mistakes is to use the provided screws.

Single 19" rack mount – Using the 2 "bracket A", it's possible to mount a single amplifier in a 19" rack.

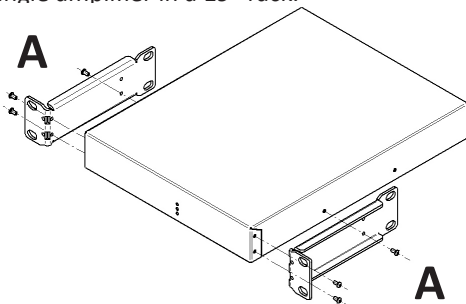

Tandem 19" rack mount – Using 1 "bracket B", it's possible to mount two Mezzo side to side and then mount them using the 2 "bracket A" in 1 RU in a 19" rack.

Unscrew the indicated screws on the first Mezzo without removing them completely, set "Bracket B" in place by slotting the screws into the keyholes, and tighten the screws avoiding overtightening. Flip both mezzo upside down, remove the pictured screws from the bottom of the second Mezzo, match the holes on "Bracket B" with the resulting screw-holes and screw back the original screws, avoiding overtightening.

Apply 2 "Bracket A" by removing the screws on each side, matching the resulting screw-holes with the holes on the bracket, and screwing back the original screws without overtightening them.

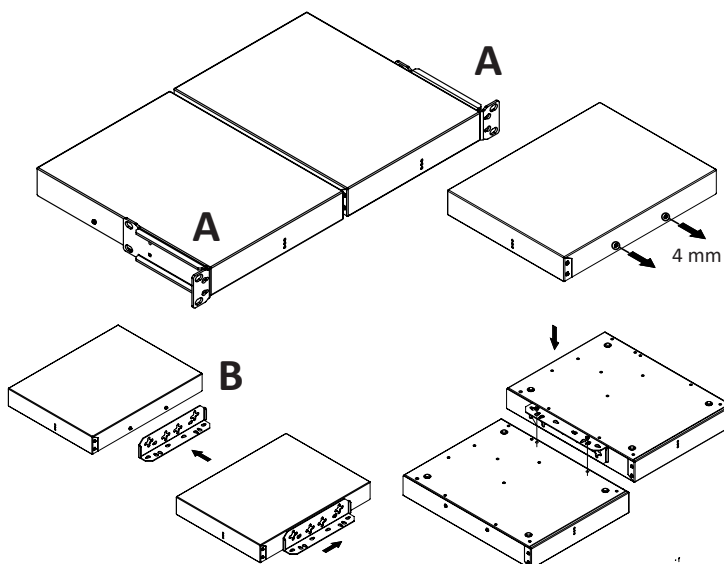

Single half rack mount – Using 2 "bracket A", it's possible to mount a single amplifier in a half width rack.

Unscrew the indicated screws (2 on each side) without removing them completely, set 2 "Bracket A" (one on each side) in place by slotting the screws into the keyholes, and tighten the screws avoiding overtightening.

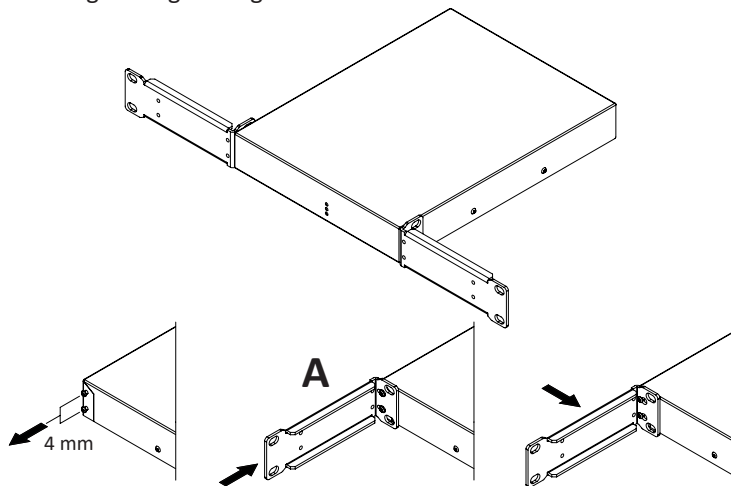

Surface mount – Using 2 "bracket B", it's possible to mount an amplifier vertically on a wall or upside down under a table or in a ceiling. In the latter case, just flip the brackets upside down.

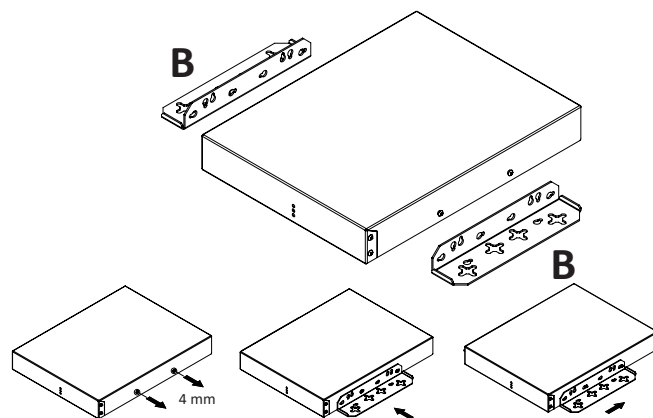

Surface mount (hidden brackets) – Using 2 "bracket B", it's possible to mount an amplifier as illustrated in the previous case, while hiding the brackets underneath Mezzo.

Use the drilling template (included in the box) to mount at least 2 screws to the wall, attach the brackets to the amplifier, then just slide it onto the wall screws.

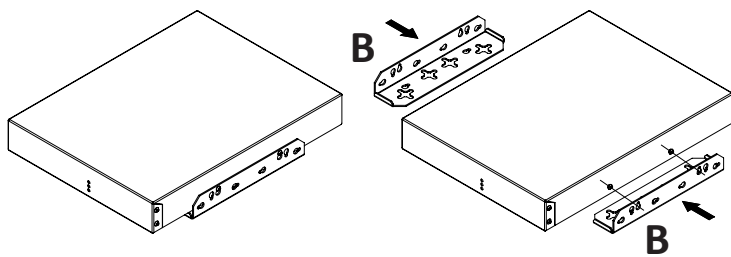

Cooling

The 600W models implement a temperature controlled forced-air cooling system. Air enters from the front and exists at the back of the amplifier. The fan has 3 modes:

STILL - if the temperature of the space surrounding the amplifier is $\leq 35^\circ$ and the average power out is ≤ 1 W per channel.

WHISPER - if the average output is ≤ 4 W per channel. The fan noise at 1 m is ≤ 30 dBA in this mode.

REGULATED - Mezzo adapts the speed of the fan to stay cool. The fan noise at 1 m is ≤ 45 dBA in this mode.

In the rare event of overheating, the amplifier will mute all channels and run the fans to reach a safe temperature and start operating again.

Set-up and Operation

Power State

This amplifier does not have a power switch. It will turn on automatically when AC power is connected and it will go to standby mode if no signal is present for 25 minutes.

When an input signal exceeding -60dB relative to the level needed for full power is applied, the amplifier will go back on within 2 seconds.

DSP and matrix configuration

The amplifier comprises a comprehensive range of functions that can be setup in two ways.

- Automatic - without the use of any app or software.
- Advanced - use the software to set more parameters and optimize the functionality.

Automatic configuration

This is a very easy way to configure the amplifier that doesn't require any software. It is ideal if all you want is an amplifier with a flat frequency response that can be monitored and, if it is an AD model, get audio routed to it with third party software.

The automatic setup will set limiters so that a channel reaches the maximum capacity of the power supply, with a 4 dBu balanced analog input (or -6 dBFS for Dante/AES67). This means that it also adjusts the gain so that the amplifier has the gain needed for all channels. The way to "assign power" is then simply done by adjusting the level of the content to the different channels.

It will also set the high-pass filters automatically. The cutoff will be selected so that frequencies below the resonance frequency, as well as frequencies that saturate transformers in Hi-Z loudspeakers, will be attenuated.

Note! Automatic configuration is only possible, and repeatable, when no amplifier settings and parameters have been manually altered. In the case of manual changes, it will still be possible to trigger the auto configuration, but for verification and monitoring purposes only. The new measured values will not be saved until settings and parameters are set back to their initial values or a factory reset is done. In order to restore Mezzo's factory default mode, start by unplugging the mains cable. Press and hold the push button on the amplifier's rear panel and reconnect the mains cable while still pressing the button. Wait for the amplifier state LEDs to blink in red for three times and release.

Step 1 - Select the maximum voltage

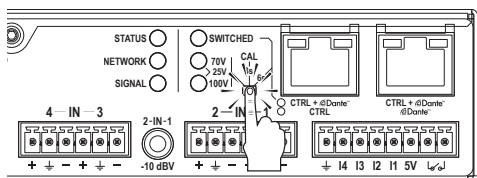

No channel will ever be assigned limiters that exceed the power of the power supply. The main reason for selecting the maximum voltage is to ensure that 25/70/100V loudspeakers will get the power selected on their tapping, if a channel is using less power than it can deliver.

If the application is 25V or 70V, then there is a risk that the limiters get set too high if the connected load isn't requiring full power. The maximum voltage can be selected with short presses on the push button on the amplifier's rear panel. The selected voltage will be displayed as follows:

70V LED	100V LED	Max Peak Voltage	Max RMS Voltage	Description
Unlit	Lit	141.4 V _{peak}	100 V _{rms}	Also works in mixed 100V and low impedance configurations
Lit	Unlit	100 V _{peak}	70.7 V _{rms}	Also works in mixed 70V and low impedance configurations
Lit	Lit	35.4 V _{peak}	25 V _{rms}	Also works in mixed 70V and low impedance configurations
Unlit	Unlit	Custom Settings		This can't be selected from the rear panel. The limiters have been set manually in the software and can't be changed without a factory reset

Please note that for low-impedance loads, it is not necessary to select the maximum voltage.

Step 2 – Calibrate

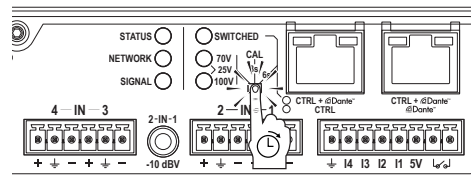

Press the push button until the 'Signal' LED turns purple, and then release it within 2 seconds. This will trigger an automatic impedance measurement for each channel. This will be made at a level that is high enough to properly measure an 8 ohm loudspeaker. If the impedance is higher, the measurement might be deemed to be too noisy and will then repeat itself automatically. Please note that it may generate an SPL exceeding 95 dB if the loudspeakers are sensitive enough. The impedance measurement will automatically set warning thresholds for monitoring changes. It will also set the limiters so that the channel can play as loud as the design and model allows, without distortion.

Step 3 - Select the Ethernet mode of operation (AD models)

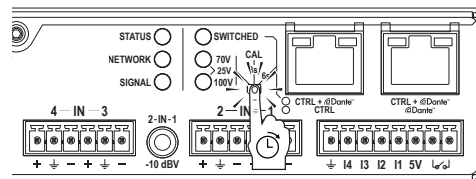

Press the push button until the 'Network' LED turns purple, and then release it within 2 seconds. This will reset the amplifier to auto-IP and it will toggle the Ethernet mode and update the "Switched" indicator:

- Unlit: The internal Ethernet switch is disabled => the two ports are not connected and the right port is then internally assigned for Dante/AES67. The left port is only for control/monitoring the amplifier's DSP.
- Lit: This is the default "switched mode". The internal Ethernet switch is enabled => the two ports are connected and will both work for Dante/AES67 and control/monitoring of the amplifier's DSP. It means that only one Ethernet cable is necessary for control and digital audio. It also means that the product can be inserted in a daisy chain of other Gigabit Ethernet products as long as there is enough bandwidth.

Step 4 - Routing and control via GPI

I/O Routing - 4-Channel models

All 4-channel models allow straight 4-in/4-out analogue routing, where analogue inputs labelled 1 and 2 are a summation of balanced and unbalanced inputs. When using unbalanced inputs only, these will get a 12dB boost so that normal unbalanced sources will deliver enough level to drive the amplifier to full power. When using both balanced and unbalanced inputs simultaneously, the latter will get a further -30dB reduction, so that priority is given to balanced sources.

I/O Routing - 2-Channel models

All 2-channel models have mixed two unbalanced inputs (labelled 1 and 2) and two balanced inputs (labelled 3 and 4), meaning that balanced and unbalanced sources can be used.

I/O Routing - Dante/AES67 (AD models)

In AD models, additional four Dante/AES67 inputs and outputs are available. For these models, the source selection strategy is enabled by default, with Dante/AES67 inputs having a higher priority over the corresponding analogue inputs when audio signal is coming from both source types simultaneously. The source selection and priority settings can be configured from ArmoniaPlus or a third-party API.

VCA Operation via GPIs

In 4-channel models, the four GPI terminals located on the amplifier's rear panel can be connected to 10kOhm passive potentiometers to attenuate the output levels. Each GPI connector (I1, I2, I3, and I4) corresponds to one output channel (1, 2, 3, and 4 respectively).

In 2-channel models, the output levels of channels 1 and 2 can be attenuated with via GPI connectors I1 and I2, respectively.

LED Charts

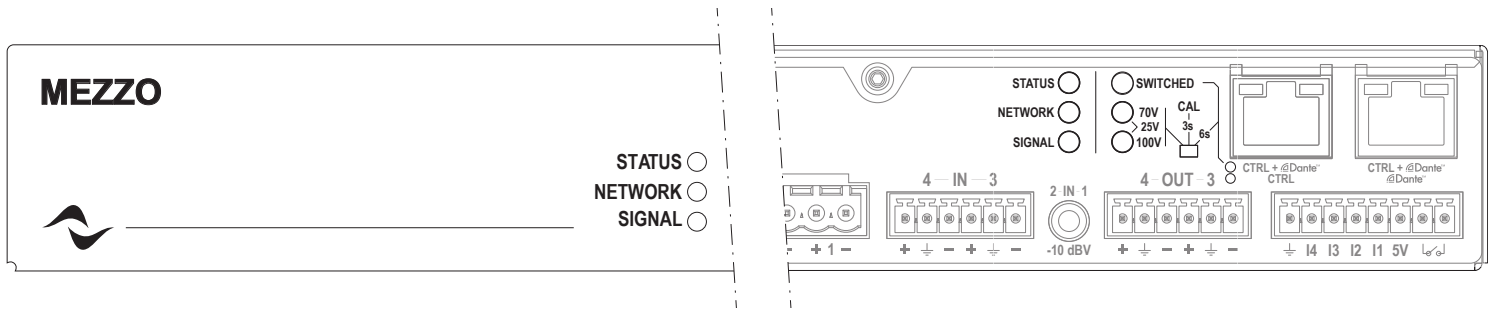

General

LED	Color	Lighting	Description
Status	Green	Solid ON	Amplifier on and operational
	Blue	Low Intensity	In standby
	Red	Solid ON	Hardware fault
Network	Yellow	Solid ON	Temperature warning
	Green	Solid ON	Ethernet up and operational
	Blue	Solid ON	Connected to remote control
Signal	Green	Solid ON	Analogue input signal present
	Yellow	Solid ON	Limiting in one or more channels
	Blue	Solid ON	Dante input signal present
Switched	Cyan	Solid ON	Both analogue and Dante input signals present
	Green	Solid ON	'Switched' ethernet operation mode enabled
	OFF	-	'Split' ethernet operation mode enabled
Status Network Signal	All Cyan	All Blinking	Amplifier selected in ArmoníaPlus or blinking command triggered.

Maximum Voltage Selection

LED	Color	Lighting	Description
70V 100V	Green OFF	Solid ON -	70V Selected
70V 100V	OFF Green	- Solid ON	100V Selected
70V 100V	Green Green	Solid ON Solid ON	25V Selected

Pushbutton LED Chart - Amplifier ON

LED	Color	Lighting	Description
Status Network Signal	OFF OFF Purple	- - Solid ON	Push button pressed for more than 2s. Auto configuration ready to be triggered following button release.
Status Network Signal	OFF Cyan OFF	- Solid ON -	Push button pressed for more than 5s. Ethernet operation mode ready to be changed following push button release.

Rear Panels

2 Channel Versions

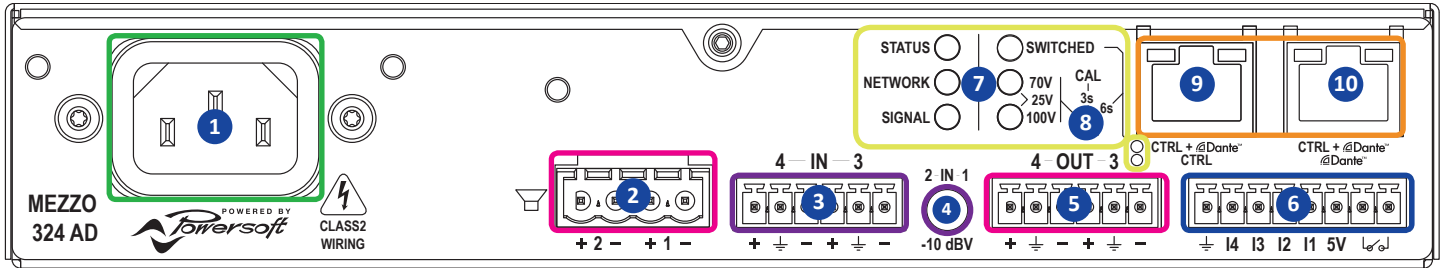

AC Mains Connector

- 1 IEC 10A

Output

- 2 CH2 - CH1 Outputs
- 5 CH4 - CH3 Line Level Balanced Outputs

Input

- 3 CH4 - CH3 Balanced Inputs
- 4 CH2 - CH1 Unbalanced Inputs

GPIO Terminals

- 6

Control & Monitoring

- 7 Amplifier State LEDs - Switched/Split mode LED (AD only)
- 8 Pushbutton

Network Connectors

- 9 1 X RJ45 Fast Ethernet connector (Mezzo A Version)
- 10 2 X RJ45 Fast Ethernet connector (Mezzo AD Version)

4 Channel Versions

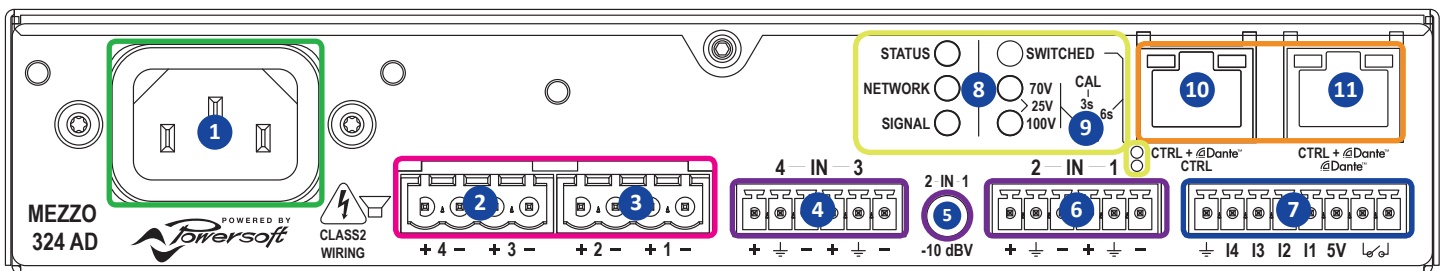

AC Mains Connector

- 1 IEC 10A

Output

- 2 CH4 - CH3 Outputs
- 3 CH2 - CH1 Outputs

Input

- 4 CH4 - CH3 Balanced Inputs
- 5 CH2 - CH1 Unbalanced Inputs
- 6 CH2 - CH1 Balanced Inputs

GPIO Terminals

- 7

Control & Monitoring

- 8 Amplifier State LEDs - Switched/Split mode LED (AD only)
- 9 Pushbutton

Network Connectors

- 10 1 X RJ45 Fast Ethernet connector (Mezzo A Version)
- 11 2 X RJ45 Fast Ethernet connector (Mezzo AD Version)



DRIVING HUMAN AUDIO EXPERIENCE

POWERSOFT S.P.A.
Via E. Conti, 5 - Scandicci (FI) 50018 - Italy
support@powersoft.com
+39 055 73 50 230
+39 055 73 56 235

[POWERSOFT.COM](https://www.powersoft.com)