

REVISIONS	
ISS	DESCRIPTION \ DATE

RoHS COMPLIANT

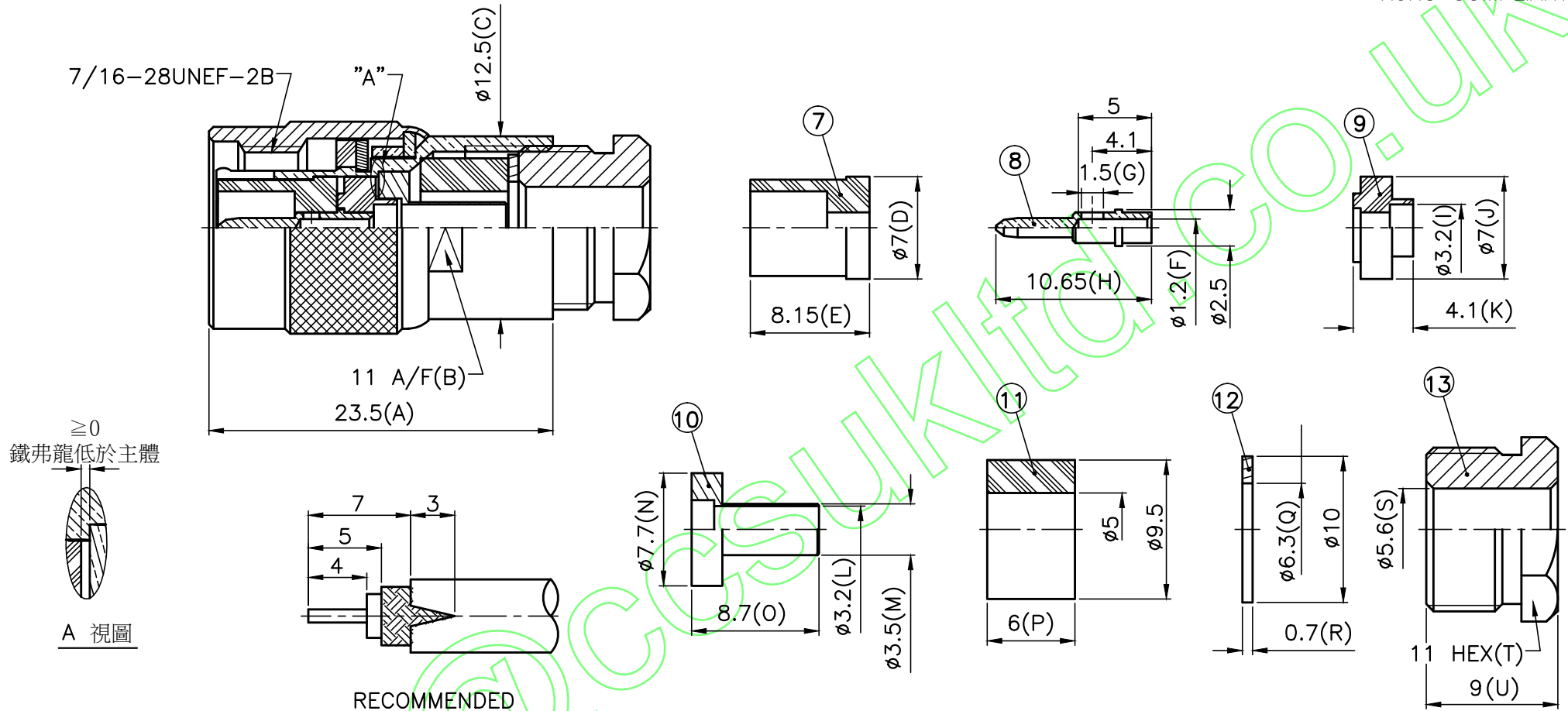

RECOMMENDED
CABLE STRIPPING DIM'S

CONNECTORS CABLES



SPECIALISTS LTD.

TITLE: TNC MALE CLAMP
(FOR RG58/U, 223/U)

PART NO: TPSC5801

030

DATE: 04/19/12"

UNIT: mm

DR. NO:

) SHEET: .

SCALE: 2.5/1

UNLESS OTHERWISE
SPECIFIED TOLERANCES
0.5-6 = ±0.2
>6-30 = ±0.4
>30-120 = ±0.6
>120-315 = ±1
>315-1000 = ±1.6
ANGLES = ±5°

13	NUT	BRASS	NICKEL
12	WASHER	BRASS	NICKEL
11	GASKET	SILICONE	WHITE
10	TOP HAT	BRASS	NICKEL
9	INSULATOR	TEFLON	WHITE
8	CONTACT PIN	BRASS	GOLD
7	INSULATOR	TEFLON	WHITE
6	WASHER	STEEL	NICKEL
5	RING	BRASS	NICKEL
4	C WASHER	STEEL	NICKEL
3	GASKET	SILICONE	RED
2	BODY	BRASS	NICKEL
1	SHELL	BRASS	NICKEL
NO.	DESCRIPTION	MATERIAL	FINISH